



YMGI, Engineered Comfort Products for A Sustainable and Efficient Green World

INSTALLER'S INSTRUCTION & USER'S MANUAL
DC INVERTER MULTIPLE ZONE (59)2
SYMPHONY CHOIR
INDOOR UNIT-RECESSED FAN COIL UNIT (EF)



WMMS-09EF-V2B(59)2

WMMS-12EF-V2B(59)2

WMMS-18EF-V2B(59)2

WMMS-24EF-V2B(59)2



YMGI Group

POB 1559

O'Fallon, MO 63366, USA

Tel: (866)833-3138 Fax: (866)377-3355

Web Site: www.ymgigroup.com

Email: info@ymgigroup.com

Literature Part No: LIT-WMMS-(59)2-EF-II & OM Manuals-20140507

Subject to Continuous Engineering Change and Product Improvement without Notice.

YMGI is the Trademark and Property of YMGI Group. Copyright of YMGI Group.



⚠ WARNING

This product is designed and manufactured free from defects in material and workmanship for the normal use and maintenance. Installation, operation, maintenance and service shall follow professional practices for regular cooling and heating equipment, NEC, State, City or Local Codes and related manuals from YMGI. Otherwise, damage to equipment or property even injury to people may occur.

Installer: Currently licensed HVAC technician only. Read manual before installation. Fully fill in warranty registration card.

User: Keep this manual for future maintenance and service use.

Service: Use this manual for service reference.



LITERATURE: LIT-WMMS-(59)2-EF-II & OM Manuals-20140507

TABLE OF CONTENTS

WELCOME AND PLEASE READ THROUGH MANUALS	2
INSTALLING TECHNICIAN/CONTRACTOR'S JOBS AND RESPONSIBILITIES	4
LIMITED PRODUCT WARRANTY POLICIES	5
LIMITED PRODUCT WARRANTY REGISTRATION CARD	6
WARRANTY AND TECHNICAL SUPPORT	7
IMPORTANT NOTES	8
INDOOR UNIT DIAGRAM	9
SPEC.SHEET	10
UNIT DIMENSIONS, MOUNTING BRACKET CLEARANCE	11
WIRING DIAGRAMS	12
RECOMMENDED TOOLS FOR INSTALLATION	13
SYSTEM LAYOUT & INSTALLATION CLEARANCE	14
INSTALLATION-LOCATION SLECTIONS	18
LENGTH AND ELEVATION LIMIT OF INSTALLATION	19
INSTALLATION-INDOOR UNITS	19
CONNECT REFRIGERANT PIPES BETWEEN INDOOR AND OUTDOOR UNITS	22
PIPING GUIDE	23
REMOTE CONTROL-BUTTON NAME & FUNCTIONS	24
OPERATION OF REMOTE CONTROL	28
OPERATION AT EMERGENCY	29
CLEAN AND CARE	29
PROTECTION SIGNS AND ERROR CODES	31
CHECKING UNITS PRIOR TO CONTACTING YOUR TECHNICIAN	31
EXPLOSIVE VIEW AND SPARE PARTS LIST	34
CUSTOMER AND TECHNICIAN MUST READ	40
USER NOTES AND INSTALLATION/SERVICE/MAINTENANCE NOTES	46

WELCOME AND PLEASE READ THROUGH MANUALS

Dear Customer(s)/End User(s)/Unit Purchaser(s)/Installer(s)/Contractor(s):

Thanks for choosing YMGI products.

The YMGI equipment you purchased is either a split-type or a self-contained cooling/heating system which requires an installer's license, certification, knowledge, experience, carefulness and details for a successful and good installation. This equipment is different from those window or portable air conditioners you can normally purchase from local retail stores such as Home Depot, Lowe's, Sears, etc. which the manufacturer may not require licensed personnel to install.

Reading and following the YMGI Group's recommendations, suggestions, and requirements, written in the following pages and other documents, is the first step to ensuring a smooth and trouble free installation & proper operation of your products for many years to come.

The quality of the installation plays a key role in whether the units will work well and for an extended period of time. The information we provide in our manuals is for the sole purpose of reminding you and your installer.

It is our ultimate goal to help insure that your YMGI units are installed properly and correctly from the very beginning to the very end. This ensures that your YMGI units will work well and not only provide a comfortable room but also peace of mind.

⚠ WARNING

YMGI doesn't recommend nor allow any do-it-yourself (DIY) installation (partially or fully), since DIY will cause problems sooner or later to your units and your upfront saving is Not saving down the road.

YMGI warranty doesn't cover any DIY units.

If you have any questions about your unit or even doubt if the unit has any problem, you can first check against the manuals. If you can not find answers, then you can contact your local installer or service technician to physically inspect the unit. If at the time of inspection the installer or service technician have any questions they can contact YMGI technical support division directly at:

Toll Free Number: (866)833-3138

Email: techsp@ymgigroup.com

IMPORTANT NOTE-YMGI HOLDS FINAL EXPLANATION:

YMGI Group, POB 1559, O'Fallon, MO 63366 is the only party who holds the final explanation (in authorized writing) about any descriptions or data in YMGI-published materials, including but not limited to YMGI product brochures, manuals, pamphlets, catalogs, videos and any other media. YMGI's distributors, installers, dealers, agents, customers or any other third parties shall not supersede YMGI to make any explanation about what YMGI-published materials mean. Any uncertainty or questions, arising from YMGI distributors, installers, dealers, agents, customers or any other third parties, should be passed directly to YMGI for an explanation in writing.

⚠ CAUTION All Units Shall Be Installed by Experienced or Licensed Contractor Or Technician. Read Manuals before Installation.

⚠ CAUTION Following NEC, State and Local Codes and Installation Instructions of All Units, Otherwise Unit Warranty Will Be Void and Serious Damage To People Or Property May Be Caused.

⚠ WARNING YMGI Group Will NOT Take Any Responsibilities for Any Damage or Loss Due to Do-It-Yourself(DIY) self-installation and other Improper Installation or Operation or Natural Disaster.

⚠ WARNING Don't Supply Power until All Wiring and Tubing and Checking is Completed. Ground the Unit Following Instructions and NEC, State and Local Codes.

⚠ DANGER Connect All Wiring Securely. Loose Wire or Other Bad Contact May Cause Arc or Overheating and Fire Hazard.



⚠ ATTENTIONS

1. Be sure to hire only one certified, licensed HVAC Company to complete 100% of the installation so that all details of the installation are clear, complete and well taken care of.
2. Be sure to have ONLY the licensed HVAC professional perform all parts of the installation. Factory Warranty will be lost if any portion of the installation is not performed by licensed HVAC contractor. DIY or partial DIY will void ALL factory warranties. One example of partial DIY would be calling the HVAC technician to release refrigerant or the sort while other installation has or is to be conducted by non-HVAC technician.
3. With hiring a technician that is offering their services as a "side job" and not through their licensed HVAC company may pose a possible risk of an incomplete or unsatisfactory installation of no guaranteed workmanship and lack of further service, if needed.
4. Have the installing technician read in full the installation manual of the product model you have. Some details may vary and some may be the key to determine the success and quality of the installation. Experience with certain manufacturer may not be applied fully to another manufacturer. For example, wiring, refrigerant adjustment and trial testing procedures may differ from manufacturer to manufacturer and model to model. Any ignoring or negligence may cause unit failure or damage which could be irrevocable and permanent.
5. All of YMGI's products are fully tested and have passed rigorous safety and performance standards and others related to the industry, before being packed and shipped. YMGI only uses famous brands as suppliers for their parts that are also known for their high quality and performance. The quality of the installation plays a key role as much as up to 90% importance in your unit's overall performance and lifetime. A poor installation can result in unit failure and inefficiency either immediately or over a period of time.
6. Some licensed contractor/technician may make a mistake some time. YMGI doesn't supervise nor is able to control their installation. It is key that the installer take each variable into account during the initial installation in order to ensure a complete and professional installation and properly working units.

⚠ WARNING

The following will cause damage to the unit and key components and the loss of your unit's factory warranty:

1. Any foreign substances introduced into the system as a result of failure of not sealing the ends of the refrigeration piping before pulling through structures at time of installation.
2. Not installing an oil P-trap in the suction copper line where indoor unit is located 18' or more below outdoor unit.
3. Cross piping and/or cross wiring on any units including more than one single zone or a multi zone system.
4. Not conducting a positive leak check by charging the system with dry-nitrogen and soap bubble testing.
5. Not conducting a negative leak check by evacuating the copper lines for 30 minutes. Vacuum must be held at 500 micron or better for at least 5 minutes, starting from 5 minutes after the vacuum pump is shut off.
6. Not conducting a positive leak check prior to the negative leak check.
7. Not selecting the correct size of wire or circuit breaker.
8. Not answering ALL questions in the technician's checklist inside the warranty registration form.

⚠ WARNING

The following may be overlooked, ignored, or treated as not a problem during your installer's installation, but actually will cause your unit to underperform or even cause unit failure.

1. Any kinks or improper bending of the copper piping.
2. Any improper flaring or not centering of the flare with the nut, or not tightening any connection.
3. Not trial testing each indoor unit individually.
4. Not reading technical data (temp/time/pressure/current) after the system is stabilized (normally compressor needs to work at least 10 minutes). Data read too early may lead to inaccurate or false judgment or even a false sense of security.

In an effort to protect our customers from any possible faulty installation which can lead to premature unit failure, we like to provide the above information to you in addition to the technician. You can judge yourself and observe while your system is being installed, though your observation may not be treated as any guarantee whether your system would be installed properly and professionally. If at any time you feel there may be an installation issue, please have your technician contact YMGI at (866)833-3138 x 703 to clear your questions.

- 1) Check with the customers to find out detailed information of structure to be conditioned, local weather (typical design and extreme temperature/humidity conditions, cooling and heating hours), previous and existing HVAC equipment, usage and dependence on the new HVAC equipment or the YMGI products.
- 2) Performing a cooling/heating load calculation by using commercially available professional programs/methods such as Right-J (Manual J) for residential HVAC applications/jobs and Right-CommLoad (ASHRAE RTS/CLTD) for light commercial and commercial HVAC applications/jobs.
- 3) Check with YMGI distributor/sales or contact manufacturer directly to obtain information to fully understand YMGI products, including but not limited to product features, cooling/heating performance-at standard ratings/conditions and extreme conditions, allowed indoor and outdoor temperature/humidity ranges, installation, operation, maintenance, service, warranty, parts and so on.
- 4) Properly select correct (most suitable) YMGI product models (of units and accessories) for your HVAC applications/jobs and list them in your proposal/quote, in writing, on your company's quote form or letter head, basing upon the information you get from 1), 2) and 3) above.
- 5) List your currently valid HVAC license # and EPA # in your proposal/quote.
- 6) Make sure you are the only party to perform the whole installation job and you will not sub-contract any part of the installation to any non-licensed parties/persons. You will be solely responsible for the full installation that you have been contracted for.
- 7) Check to make sure you have all the materials you need to properly and correctly finish the installation. The YMGI units and accessories may be just a portion of what you need. YMGI employees and YMGI distributors/sales, dealers and agents are not installers and may only be able to provide suggestions to you, but you are the only sole decision maker to determine what other materials you must need and/or the customer may want to fulfill the installation job.
- 8) Check against both NEC and your local codes to make sure all the installation of YMGI units and accessories meet these requirements.
- 9) Connect the unit to correct electrical power source. In the area where lightning or storm incurs frequently, a proper type/size of power surge protector needs to be installed between the outdoor unit and power source.
- 10) Select proper types and sizes of HVAC circuit breakers, disconnect switch boxes, wires and conduits from circuit breaker to disconnect box and then from disconnect box to outdoor unit.
- 11) Select proper location to mount indoor units and outdoor units with all factory requirements being followed (cooling/heating/air is not blocked or restricted, mounting structure is secure, aesthetical looking, installation convenience is considered, maintenance/service clearance is ensured and all applicable codes are met and etc.).
- 12) Cap/tape the two ends of every copper line before running them through structures to keep from any foreign substances entering into pipe and causing contamination. Label them A-A, B-B, C-C, D-D, or other marks on each pair of copper line/wiring cable set to keep from any possible cross-piping or cross-wiring in multiple zone installations or where pipes for different single zone systems are close to one another.
- 13) Secure the wiring cables that connect between indoor unit and outdoor unit, following applicable NEC and local codes for your particular installation. If there is no special NEC or local code to govern how these wires are to be installed, you can tape/cable tie them along with insulated copper line.
- 14) Tighten all pipe and wire connections to keep from any possible leakage or false connection.
- 15) Conduct positive pressure leakage checking of inter-connecting copper lines between each indoor unit and outdoor unit by charging dry-nitrogen at outdoor unit service port (note: don't back-seat stopping valve, at this time). Liquid soap solution shall be applied at all pipe connections to check for leakage. A 1/4-5/16" hose/valve adaptor may be needed if you have traditional manifold of 1/4" connection hose.
- 16) If there is no positive leaking, then conduct negative pressure leakage checking of inter-connecting copper lines between each indoor unit and outdoor unit by pulling vacuum at outdoor unit service port (note: don't back-seat stopping valve, at this time) and checking if the vacuum level 500 Micron can be held for at least 20 minutes.
- 17) If there is no leakage found at refrigeration pipe connections, flip up the indoor unit face panel and remove filter, carefully pour some clear water onto the up-right aluminum coil surface to test if the water can drain out of each indoor unit freely without any leakage being found.
- 18) If there is water leakage found, locate the source of the leak and correct. Only after everything is clear engage the correct electrical power to the system.
- 19) Then back-seat stopping valves of outdoor unit to release refrigerant from outdoor unit into inter-connecting pipes and indoor unit.
- 20) Check to make sure both indoor unit and outdoor unit are powered on correctly before controlling the indoor unit to operate in fan mode first. Then move on to test cooling, dehumidifying/drying, heating and other modes.
- 21) Read refrigerant pressures and pipe/valve temperatures only until the system is stabilized (normally 10 minutes after cooling/heating mode is started successfully). Put this data into the technician checklist in the lower half section of the Limited Product Warranty Registration Card/Form.
- 22) Adjust refrigerant charging level (remove refrigerant if pipe is shorter/temperature is colder; add refrigerant if pipe is longer/temperature is warmer), following manufacturer's instructions, if average pipe length is shorter or longer than 25' and pressure/temperature readings at outdoor unit service valves are not falling into normal ranges.
- 23) Explain to the user/owner(s) about proper unit operation and maintenance and leave your contact information for them to reach you easily.
- 24) If the customer finds the unit doesn't work properly and cannot resolve the issue themselves, check the customer's units/parts/accessories and correct the problem if there is any. Communicate with YMGI-technical support line (866)833-3138 x 703, if needing help.

Following these requirements will aid in ensuring the units to be installed to the general HVAC practicing standards and necessary factory requirements, finding any possible problems early, preventing any further damage to the unit and helping ensure a properly working unit over its lifetime.

LIMITED PRODUCT WARRANTY POLICIES

The YMGI products are designed and manufactured free from defects in workmanship, and materials for normal use. However, for any reason, including many handlings and occasions between the YMGI factories/warehouses and where you receive the products, the unit doesn't work, YMGI Group will help to remedy the occurrence in the following warranting ways:

Compressor: YMGI will warrant the compressor of YMGI-validated and approved warranty filing, for a period of 5 years from the date of successful installation at original location.

Parts: YMGI will warrant parts of YMGI-validated and approved warranty filing, for one year from the date of successful installation at original location.

All warranty compressors and parts replaced will become the sole property of YMGI Group and must be returned to YMGI Group upon request. Warranty parts may be new or refurbished. All parts are tested and approved before shipping.

At no time does the YMGI Group warrant labor cost of any type. Warranty will start from the date of successful installation at initial location, or 90 days as of original shipping date from YMGI Group, whichever comes first.

This is a standard warranty of limited liability and DOES NOT cover the following:

- * Any damage or repairs to properties, or persons as an incident or consequence of improper or faulty transportation, installation, operation, maintenance or service.
- * Damage caused by frozen or broken water hoses or refrigeration pipes in the event of equipment failure.
- * Any damage as a result of floods, fire, wind, lightening, accidents, corrosive atmosphere or any other conditions beyond the control of YMGI Group.
- * Any damage due to interruption or inadequate electrical service to equipment.
- * Any products that are installed outside the US or Canada.
- * Any unit that has been moved from the original installation address.
- * Any labor costs associated with the installation or service of the unit.
- * Poor unit performance due to improper unit selection (SEER, Unit size).

To validate the above warranties, ALL the following conditions must all be fulfilled:

1. The unit was fully (100%) and successfully installed by licensed or certified HVAC technicians.
2. The unit was installed following all NEC, state and local codes.
3. The unit was installed following all instructions and manuals made by YMGI Group.
4. ALL fields, especially the technician-checklist, of the **Limited Warranty Registration Card/Form** were filled completely by the installing technician and signed by both the installing company technician and the unit owner.
5. The **Limited Warranty Registration Card/Form** and a copy of the original installing company's invoice had been received by YMGI Group-Warranty Dept., POB 1559, O'Fallon, MO 63366, within 7 days of successful installation.

No warranty filing will be validated or approved, if any one of the above 5 conditions is not met.

Product registration doesn't guarantee the validity of this limited warranty statement.

Steps to follow for warranty part replacement:

1. Installing or service technician contacts YMGI tech support at 1-866-833-3138 ext 703 from the jobsite, to double-check and confirm with YMGI Technical support the exact part(s) needed to fix all the problems.
2. YMGI will check the customer's warranty filing. Parts for validated and approved warranty will not be charged. Parts of invalid warranty filing or unapproved warranty requesting, will be charged accordingly.
3. YMGI will ground ship out the parts ASAP. Expedited shipping is available at the customer's cost.
4. Replacement parts of approved warranty registration are to be warranted for the remainder of the 1 year parts and 5 year compressor warranty. Purchasing of replacement parts of invalid warranty filing or unapproved warranty requesting, will be as they are and bear no warranty.

YMGI keeps on improving products with various engineering changes without prior notice. Such improvements or changes include but not limited to product specification, appearance, functions, sizes, packaging and others. These improvements or changes will not void the limited warranty stated herein. YMGI keeps the final explanation of this warranty policy.

LIMITED PRODUCT WARRANTY REGISTRATION CARD



YMGI GROUP
Innovative, Competitive, Efficient & Convenient

LIMITED PRODUCT WARRANTY REGISTRATION CARD / FORM

YMGI to Fill Top Portion, at Shipping, and Keep Copy A; Center Copy B for Installer to Fill and Mail back to YMGI; Bottom Copy C for Customer to Fill and Keep

For YMGI Use Only	The Company the Unit Was Sold Through: _____	Shipping Packing List Number: _____	Registration Card Serial No. _____	
	Did the Company Pay to YMGI: _____	HVAC Contractor/Technician--Name _____	Date the Filled Registration Card YMGI Received: _____	
	Installation Invoice Attached to the Registration Card _____	Hired YMGI-Recommended HVAC Contractor/Technician? _____	Unit(s) Work Successfully (Yes/No): _____	Warranty Approved _____

Outdoor Serial Number (One Outdoor Unit, One Registration Card/Form): _____	Indoor Serial Number: _____	For Multi Zone Units _____	Unit #1 _____	Unit #5 _____
			Unit #2 _____	Unit #6 _____
			Unit #3 _____	Unit #7 _____
			Unit #4 _____	Unit #8 _____

Contact Where the Units are Installed:

Name: _____ Phone: _____ Fax: _____

Address: _____ Email: _____

City: _____ State (Province): _____ Country: _____

Contact of the Installing HVAC Contractor/Technician:	YMGI-Recommended Contractor/Technician:
Technician Full Name (Print): _____	Phone/Fax: _____
HVAC Technician's Company Name: _____	Email: _____
Address: _____	City:State (Province): _____
Currently Licensed or Certified HVAC Technician License or Certification Number: _____	License Approved or Certified by: _____
Official Phone # to Check the License Validity: _____	

List for Installing HVAC Technician to Double Check Installation Quality, and Warranty Processing Purpose (if not filled by technician, or not filled fully, warranty will void)

- | | |
|---|---|
| 1) Are you the only one to install whole system? If not, % of installation done by you (HVAC technician). | 2) What had been done, prior to your arrival? |
| 3) Did you read the User Manual and Installation Instruction, before you started the installation? | 4) Who unpacked the unit and accessory boxes to check for damage? |
| 5) Supply electrical power V/Ph/Hz measured at wiring terminal block of indoor unit: _____ outdoor unit: _____ | 6) Incoming electrical power V/Ph/Hz measured at terminal blocks of indoor unit: _____ outdoor unit: _____ |
| 7) Wire gauge, length and terminal colors between circuit breaker/disconnect switch to outdoor unit: _____ | 8) Wire gauge, length and terminal colors between each indoor and outdoor unit: Unit A _____ Unit B _____ Unit C _____ Unit D... |
| 9) The size of HVAC circuit breaker/fuse or disconnect switch to the outdoor unit: _____ | 10) Are the inter-connecting wires and copper lines between indoor and outdoor units installed/covered/protected by line set covers, or anything else? |
| 11) What is the refrigerant pipe length between each indoor unit and the outdoor unit? Unit A _____ Unit B _____ Unit C _____ Unit D... | 12) Where is/are the indoor unit(s) located? Unit A _____ Unit B _____ Unit C _____ Unit D... |
| 13) What is the elevation difference between each indoor unit and the outdoor unit? Unit A _____ Unit B _____ Unit C _____ Unit D... (indoor unit above outdoor unit +, below -) | 14) Did you check the indoor unit for condensate leakage and refrigerant leakage, before and after connecting them? |
| 15) Where is the outdoor unit located? Ground wall balcony roof other _____ Is the outdoor unit anchored to ground or secured onto wall location or pad _____ bracket? | 16) Have you checked to make sure there is no cross-piping and no cross-wiring between any two indoor units (zones)? How did you do it, who was with you? |
| 17) Were the refrigerant pipe ends capped or taped seal, prior to running them through structures to keep debris from entering the copper lines? | 18) Have you checked and run cooling or heating, one unit by one unit, all working fine? |
| 19) Did you charge the inter-connection copper pipes and indoor unit with nitrogen to check for positive leakage (pressures 150-200PSI), before conducting vacuuming leakage check? | 20) Did you vacuum correctly to check the connecting pipes and indoor unit for leakage, what was the micron gauge reading, for how many minutes? |
| 21) Did you check if the compressor can be started and stopped in a correct (design) manner? | 22) If copper length were not made to the supplied or recommended refrigerant pipe length, how much refrigerant added or deducted? |
| 23) Measured refrigerant pressures at outdoor service suction valve, when unit was st. Heat pump (PSI): _____ Cooling (PSI): _____ Outdoor Ambient Temp. (°F): _____ | 24) What were the measured temperatures (probe not touching any metal): At cooling: indoor return air °F, discharge air °F, and outdoor °F At heating: indoor return air °F, discharge air °F, and outdoor °F |
| 25) Have you checked all unit functions, with customer's witness, and all functions are correct? | 26) Did you show the user how to operate the unit? Did he/she understand you? |
| 27) Do you provide regular one-year free technical service for this installation? | 28) Do you list the working details in the invoice and leave a copy to the customer? |

Installation Finished and Unit Works Successfully. Print Name of Installation HVAC Technician: Signature: _____	Installation Finished and Unit Works Successfully. Print Name of Owner: Signature: _____
Date and time: _____	Date and time: _____

By signing above, I acknowledge the liability and responsibility for any false statement or not telling all the facts, and I authorize YMGI to check the details of the filled above, and make its decision on warranty. I understand our filing or filling the warranty card/form DOESNT mean automatic warranty approval, because warranty is approved only to those qualified and successful installations by qualified HVAC technician. I know the warranty, if approved, is a standard 5-year compressor and 1-year other parts only, without any labor coverage. I agree to and will follow all the contents contained in the Limited Product Warranty Policy that YMGI, not other entity, stated in public, including but not limited to manuals, web site, email, etc.

Important Note: A copy of the installing HVAC company's invoice to show all their work details, your payment proof, center copy B of this registration card filled after a successful installation, all three (3) MUST be mailed together to Warranty Dept., **YMGI Group, POB 1559, O'Fallon, MO 63366**, for warranty processing. Customer keeps bottom copy C. YMGI will check against copy A that was kept at YMGI.



WARRANTY AND TECHNICAL SUPPORT

YMGI warrants to the purchaser/owner(s) that YMGI products be free from defects in material and workmanship under the normal use and maintenance, with the standard Limited Product Warranty Policies that comes with the unit or sales package.

YMGI IS NOT RESPONSIBLE FOR

- * Damage or repairs required as a consequence Customer do-it-yourself(DIY) installation and/or any other faulty installation or improper application.
- * Damage or repairs needed as a consequence of any misapplication, abuse, improper servicing, unauthorized alteration, or improper operation.
- * Damage as a result of floods, winds, fires, lightening, accidents, corrosive atmosphere, or other conditions beyond the control of YMGI.
- * Any damages to person or property of whatever kind, direct or indirect, special or consequential, whether resulting from use or loss of use of the product.
- * Failure to start due to voltage conditions, blown fuses, open circuit breakers, or other damages due to the inadequacy or interruption of electrical service.
- * Parts not supplied or designated by YMGI.
- * Products installed outside USA or Canada.
- * Regular equipment maintenance or field service or field inspection.
- * Any problems due to improper cooling and heating load calculation of the room/building the air conditioner/heat pump system is to be installed. Equipment users can get the calculation schedule from your room/building architect or your installation or related service HVAC contractor, who should have the knowledge and the tools to do these calculations correctly.
- * Any problems due to improper sizing and selecting air conditioner/heat pump system. These equipment sizing and selection work should be conducted by either your room/building architect or your installation or related service HVAC contractor, who should have the knowledge and the tools to do these calculations correctly, and get your approval, before purchasing the air conditioner or heat pump equipment.
- * Any problems due to improper installing of the air conditioner/heat pump system. Installation should be conducted by currently licensed HVAC technician, following manufacturer installation instructions, all governing safety codes, with care and professionalism.
- * Any problems due to improper operation of the air conditioner/heat pump system. Users shall keep the manual and refer to it for the correct understanding of how the unit will work and how to operate the unit correctly.
- * Any problems due to improper maintenance of the air conditioner/heat pump system. Like a car, regular maintenance or yearly checking is necessary for the unit to work properly for you, before the season comes. For example, air filter shall be checked for cleanliness from time to time. Remote control batteries shall be checked for enough power, before judging the unit is not working...

CONTACT FOR FIELD SERVICE OR REPAIR

The following people, in a prioritized sequence, will take care of your request or issue:

- 1) The original installer; otherwise,
- 2) Your current service contractor; otherwise,
- 3) Authorized contractor in YMGI list that is close to you; otherwise,
- 4) Authorized Distributor in YMGI Distributor list; otherwise,
- 5) Contractor/Distributor you prefer who is close to you.

CONTACT FOR GENERAL TECHNICAL QUESTIONS OR SUPPORT, IN A SEQUENCE:

- 1) The original installer; otherwise,
- 2) The current service contractor; otherwise,
The original licensed installer or current service contractor should be contacted first of all, since they installed the unit and/or know more details than anybody else.
They will check the unit and find out the problems with the professional knowledge about HVAC and electric product installation by using special tools or instrument.
They can contact YMGI technical support for technical help during unit installation or inspection.
Product model and serial numbers needed, which can be found on unit nameplate sticker, so that our technician can quickly identify the unit, parts and wiring diagrams, among our many products and models.
- 3) The distributor; where the unit is purchased from otherwise,
- 4) YMGI Technical Support:
Tel: (866) 833-3138*703 Email: techsp@ymgigroup.com

CUSTOMER AND TECHNICIAN MUST READ

WHY DOES YMGI GROUP REQUIRE INSTALLATION AND SERVICE TO BE 100% PERFORMED BY LICENSED OR CERTIFIED HVAC TECHNICIAN/ CONTRACTOR?

- 1) **They have the training and experience to accurately and safely install and service your equipment.**
The equipment runs with high-pressure refrigerant and oil and line-voltage. The copper lines must be installed properly to prevent leakage and foreign substances from contaminating the refrigerant system.
- 2) **You will save money in the long run.** If any problems occur on the unit that is fully installed by the licensed or certified contractor, they have the training and experience to correct the problem more efficiently. A technician(s) may be unwilling to repair an issue on a unit that they did not install. If you do find a technician willing to perform the service, there is an increased possibility of higher service fees than normal, increased service visits, or delayed service from that technician.
- 3) **It's the law!**
The federal, state and/or local government and authorities have various governing laws or regulations, guidelines, ordinances, etc., requiring only licensed or certified professionals can install and service high pressure HVAC equipment.

SUGGESTIONS, TO AID YOU IN HIRING AN HVAC CONTRACTOR:

- 1) Hire a currently, practicing, licensed/ certified HVAC technician/ contractor. Technicians, who are no longer practicing (retired, etc.) in this field, may not have the updated knowledge or may lack experience on the equipment you have purchased.
- 2) Hire a technician/ contractor who services customers in your local area and you are familiar with. Local contractors have a faster response time and will be easier for you to determine if they are reputable.
- 3) Use only reputable licensed/ certified HVAC installation contractors/ technicians to prevent any unexpected charges as a result from unethical business practices.
- 4) Check their references, to verify they are a good service provider to the general customers. N.A.T.E or A.C.C.A certified technicians are strongly recommended.
- 5) Some contractors/ technicians may not feel comfortable about installing the equipment that you purchased for them to install, and they prefer to purchase and install the equipment. You can contact YMGI directly to check and see if there have been any contractors in your area who have installed our products or similar.
- 6) Ask for a detailed quote for the whole installation project. A flat rate quote is the safest contract for both you and the contractor
- 7) Your local HVAC technicians may charge you on a project basis or on an hourly basis. To our general knowledge and experience, **a full single head installation may normally cost anywhere from \$800 to \$1500**. These costs are estimates and your actual costs may differ due to job nature and location.
- 8) Number of hours can vary depending upon each individual situation, some factors are, but not limited to:
- 9) How difficult or complex the indoor unit is to be securely installed.
- 10) How difficult or how long the inter-connecting pipes and wires are to be installed.



UNIT PICTURE & WORKING TEMP. RANGES



Rated Working Conditions

Table 8 Working Temperature Range

	Indoor side state °F (°C)		Outdoor side state °F (°C)	
	Dry bulb temp. °F (°C)	Wet bulb temp. °F (°C)	Dry bulb temp. °F (°C)	Wet bulb temp. °F (°C)
Rated. Cooling	80.0(26.7)	67.0(19.4)	95.0(35.0)	75.0(23.9)
Max. cooling	80.0(26.7)	67.0(19.4)	115.0(46.1)	75.0(23.9)
Min. cooling	67.0(19.4)	57.0(13.9)	67.0(19.4)	57.0(13.9)
Rated. Heating	70.0(21.1)	60.0(15.6)	47.0(8.3)	43.0(6.1)
Max. heating	80.0(26.7)	—	75.0(23.9)	65.0(18.3)
Low Ambient heating	70.0(21.1)	60.0(15.6)	5.0(-15.0)	3.2(-16.0)

SPECIFICATIONS

Items	Unit / Conditions	WMMS-09EF-V2B(59)2	WMMS-12EF-V2B(59)2	WMMS-18EF-V2B(59)2	WMMS-24EF-V2B(59)2
Power Supply	Voltage/Ph/Hz	208-230/1/60	208-230/1/60	208-230/1/60	208-230/1/60
	Allowed Voltage Range	187-253V	187-253V	187-253V	187-253V
Cooling Capacity (Btu/h)	High/Standard/Low	10700/8500/4600	14100/11900/5900	21500/15300/6800	26500/23800/9600
	ID 70/60, OD 47/43F	9500	13100	18700	27400
Heating Capacity (Btu/h)	ID 70/60, OD 17/15F	8800	11600	16600	23600
	ID 70/60, OD 17/5F	8000	9100	13800	20600
SEER	Btu/h.W	16	16	16	16
HSPF	Btu/h.W	8.2	8.2	8.2	8.2
Dehumidifying Capacity	Pints/Hr.	1.7	2.96	3.8	5.28
Air Flow (CFM)	High/Medium/Low	260/180/150	320/240/180	410/350/295	590/440/320
Air-throw (Ft.)	Horizontal Installation	25-20 Upon Mounting Height/Speed/Temp.			
External Static Pressure	Water In.	0	0	0	0
	Pressure dB(A) (H/M/L)	37/34/31	39/35/32	41/37/33	42/38/34
Sound Level	Power dB(A) (H/M/L)	47/44/41	49/45/42	51/47/43	52/48/44
	Model	FG30A	FG40A	FG60A	FG20E
Fan Motor	Shaft	Double	Double	Double	Double
	Speed (RMP, H/M/L)	970/760/640	960/830/700	920/780/720	985/800/680
	Output (W)	40	49	75	2 x 45
	Input (W)	80	90	100	2 x 85
	Capacitor (uF)	1	3	3	3
Fan Wheel	Type-Piece	Centrifugal-2	Centrifugal-2	Centrifugal-2	Centrifugal-4
	Diameter x Width (In.)	5.5 x 5.3	5.5 x 5.3	5.5 x 5.3	5.5 x 5.3
Swing/Step Motor	Model	NA	NA	NA	NA
	Piece	NA	NA	NA	NA
	Output (W)	NA	NA	NA	NA
Input Power of Ele. Heater	Type-W	NA	NA	NA	NA
Electrical Protection Fuse	PCB/Transformer	T3.15A 250V / 0.2A			
Evaporator Coil	Type	Alu. Fin/Inner Grooved Copper Tube			
	Color	Blue	Blue	Blue	Blue
Copper Line Connections	Sealed by Dry Nitrogen	Yes	Yes	Yes	Yes
	Flare/Nut-Liquid + Gas	1/4" + 3/8"	1/4" + 3/8"	1/4" + 1/2"	1/4" + 5/8"
Drain Hose Connection	OD (In.)	1	1	1	1
Condensate Pump	Installed-Lift (In.)	NA	NA	NA	NA
Refrigerant Environmental Friendly	R410A	Yes	Yes	Yes	Yes
Filter	Type-Feature	Standard-Washable	Standard-Washable	Standard-Washable	Standard-Washable
	Size WxH (In.) - Qty.	23.7 x 7.6 - 1	23.7 x 7.6 - 1	31.6 x 7.6 - 1	39.4 x 7.7 - 1
Clean Coil Surface	Anti-Mildew Function	Yes	Yes	Yes	Yes
Pre-heating Function	Anti-Cold Blowing	Yes	Yes	Yes	Yes
Memory of Previous Set-ups	Power is Lost/Resumed	Yes	Yes	Yes	Yes
Auto-Restart Function	If Power is Resumed	Yes	Yes	Yes	Yes
Unit Dimensions	Net WxHxD (In.)	27.6 x 24.2 x 7.9	27.6 x 24.2 x 7.9	35.4 x 24.2 x 7.9	43.3 x 24.2 x 7.9
	Package WxHxD (In.)	35.0 x 29.1 x 11.4	35.0 x 29.1 x 11.4	44.0 x 29.1 x 11.4	52.0 x 29.1 x 11.4
Unit Weight	Net (LBs)	48	51	59	68
	Packaged (LBs)	59	64	79	90
Loading Capacity	20"/40"/40"HQ	108/234/234	108/234/234	90/192/192	72/162/162

INSTALLING LOCATION

LOCATION

- 1) Do not place object near the air outlet so that conditioned air can reach the whole room.
- 2) Be sure to install the indoor unit firmly and horizontally.
- 3) Select a place that can support 4 times the weight of the indoor unit and will not increase noise and vibration.
- 4) Select a place easy to drain water and connect with the outdoor unit.
- 5) Make sure there is enough space for maintenance and make sure the distance between the unit and ground is 1.8m or more.
- 6) Make sure the suspension bolt pitch can hold 4 times the weight of the indoor unit, otherwise, you should strengthen the suspension bolt pitch.

Note:

1. Keep enough distance from the kitchen.
2. The appliance shall not installed in the laundry.

Installation of the Indoor Unit

(1). Requirements on the Installation Location

- 1) Ensure the hanger is strong enough to withstand the weight of the unit.
- 2) The drainage pipe is easy for connection.
- 3) No obstacle is in the inlet/outlet and the air circulation is in good condition.
- 4) Ensure the installation space shown in Fig.2 is left for the access to maintenance.
- 5) It should be far away from where there is heat source, leakage of inflammable, explosive substances, or smog.
- 6) It is the ceiling type unit (concealed in the ceiling).
- 7) The power cords and connection lines of the indoor and outdoor units must be at least 1m away from the TV set or radio to avoid the image interference and noise (even if 1m is kept, the noise may be produced due to the strong electromagnetic wave).

Dimension Requirements on the Installation Space of the Indoor Unit

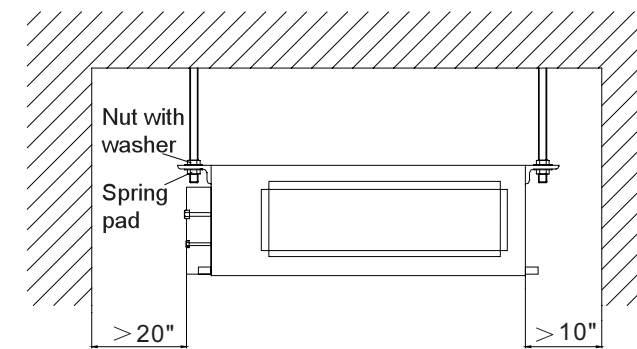

Fig. 2

INSTALLING DIMENSIONS AND CLEARANCE

Installation Instructions

Outline Dimension Drawings of the Indoor Unit

Note: the unit in the followings figures is mm, unless otherwise specified.

Fig.1 is applicable to WMMS-09EF-V2B(59)2 / WMMS-12EF-V2B(59)2 / WMMS-18EF-V2B(59)2 / WMMS-24EF-V2B(59)2:

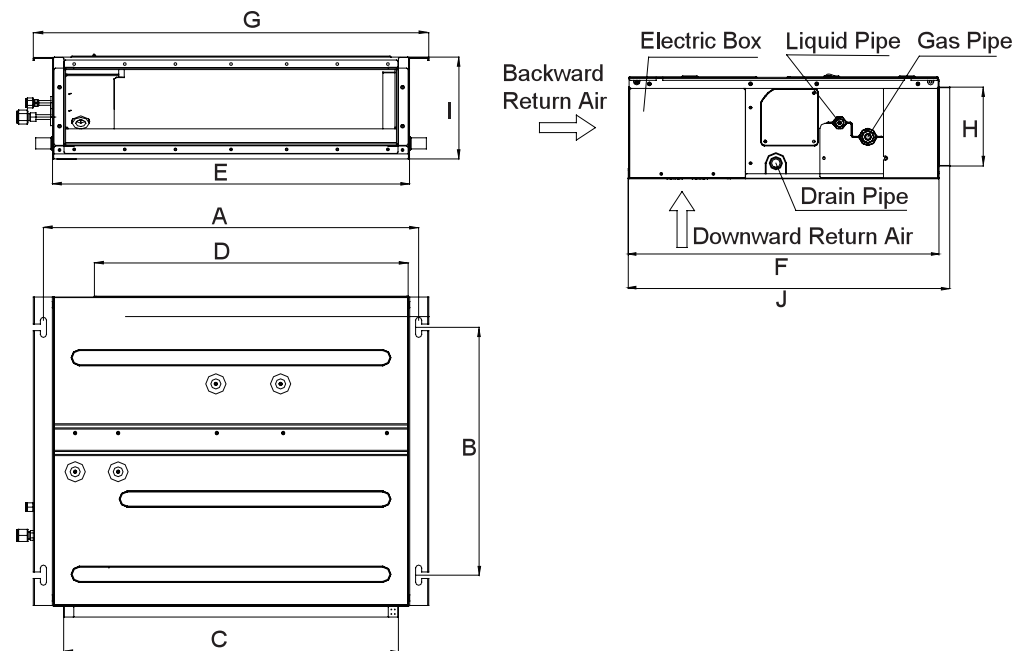

Fig.1

Table 1: Outline Dimensions

Model \ Item	A	B	C	D	E	F	G	H	I	J
WMMS-09EF-V2B(59)2	29.2	19.3	26	24.4	28	24.2	31	6.1	8	25
WMMS-12EF-V2B(59)2	29.2	19.3	26	24.4	28	24.2	31	6.1	8	25
WMMS-18EF-V2B(59)2	37.1	19.3	34	32.3	35.4	24.2	39	6.1	8	25
WMMS-24EF-V2B(59)2	45	19.3	42	40.1	43.3	24.2	46.5	6.1	8	25

MOUNTING UNITS

(2). Installation of the Indoor Unit

Insert the M10 expansion bolt into the hole, and then knock the nail into the bolt. Refer to the Outline Dimension Drawings of the Indoor Unit for the distance between holes and see Fig.3 for the installation of the expansion bolt.

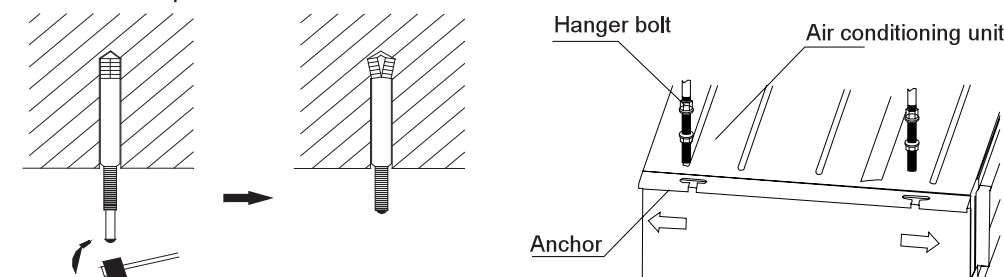

Fig.3

Fig.4

Install the hanger on the indoor unit, as shown in Fig.4.
Install the indoor unit on the ceiling, as shown in Fig.5.

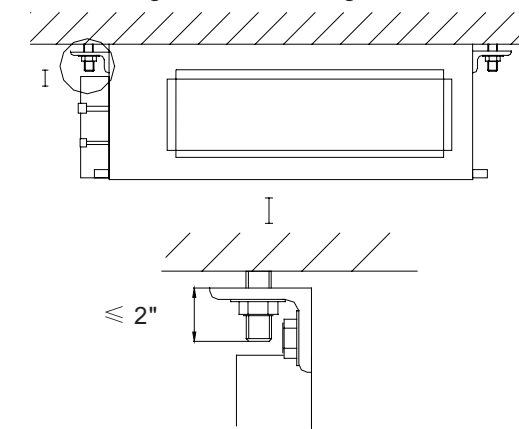

Fig.5

⚠ CAUTION!

① . Prior to the installation, please make a good preparation for all piping (refrigerant pipe, drain pipe) and wiring (wires of the wired controller, wires between the indoor and outdoor unit) of the indoor unit to make the further installation much easier.

② . If there is an opening in the ceiling, it is better to reinforce it to keep it flat and prevent it vibrating. Consult the user and builder for more details.

③ . If the strength of the ceiling is not strong enough, a beam made of angle iron can be used and then fix the unit on it.

④ . If the indoor unit is not installed in the air conditioning area, please use sponge around the unit to prevent condensing. The thickness of the sponge depends on the actual installation environment.

Horizontality Check of the Indoor Unit

After the installation of the indoor unit, its horizontality must be checked to make sure the unit keep horizontal fore and aft and keep an inclination of 5° toward the drain pipe right and left, as shown in Fig.6.

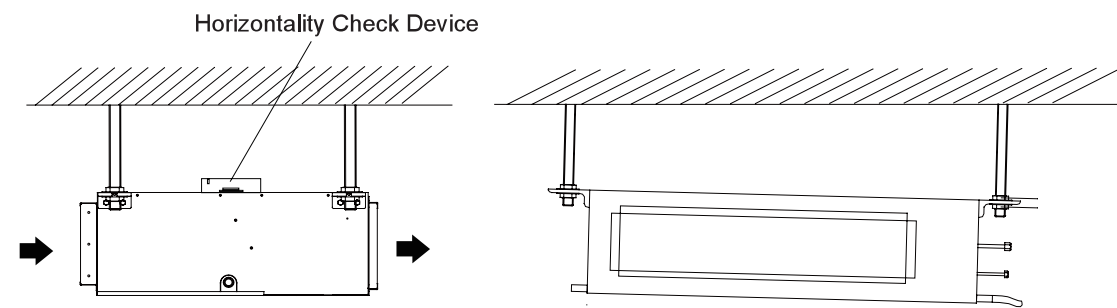

Fig.6

CONNECTING AIR DUCTWORK

Installation of the Air Supply Duct

(1). Installation of the Rectangular Air Supply Duct

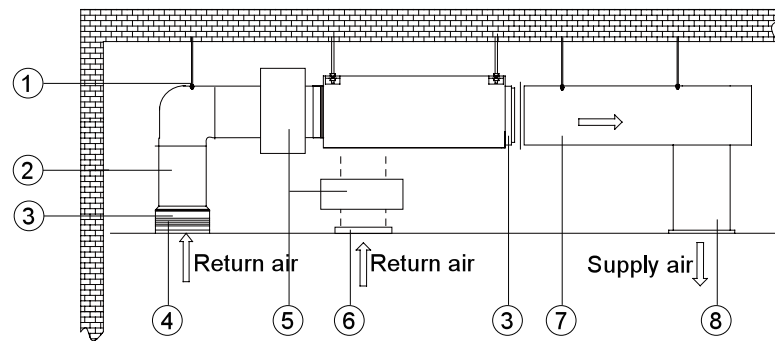
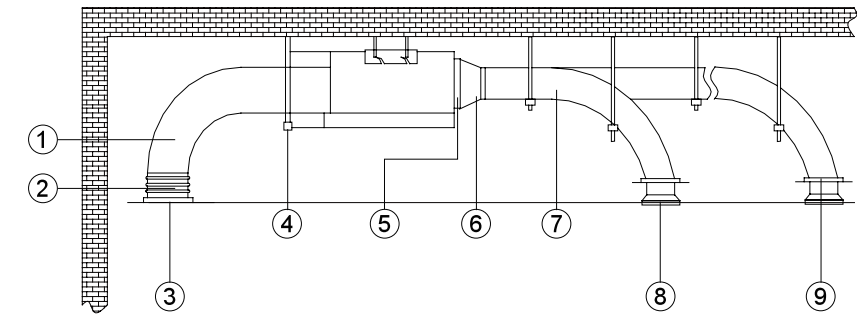

Fig.7

Table 2

No.	Name	No.	Name
1	Hanger	5	Plenum Box
2	Return Air Duct	6	Filter Screen
3	Canvas Duct	7	Main Air Supply Duct
4	Return Air Inlet	8	Air Supply Outlet

(2). Installation of the Round Air Supply Duct



g.

Table 3

No.	Name	No.	Name
1	Return Air Duct	6	Transition Duct
2	Canvas Duct	7	Air Supply Duct
3	Return Air Louver	8	Diffuser
4	Hanger	9	Diffuser Joint
5	Air Supply Outlet		

(3). Installation Steps of the Round Air Supply Duct

- 1). Preinstall the outlet of the round duct on the transition duct and then fix it by the tapping screw.
- 2). Place the transition duct to the air outlet of the unit and fix it with rivet.
- 3). Connect the outlet to the duct and then tighten them with tape. Other installation details are not covered herein.

CAUTION!

- ① . The maximum length of the duct means the maximum length of the air supply duct plus the maximum length of the return air duct.
- ② . For the unit with the auxiliary electric heating function, if the round duct is to be adopted, then the straight length of the transition duct can not be less than 200mm.
- ③ . The duct is either rectangular or round and connected with the air inlet/outlet of the indoor unit. Among all air supply outlets, at least one should be kept open. As for the round duct, it needs a transition duct of which the size should match with the air supply outlet of the unit. After the fitting of the transition duct, it is the turn of the round duct, which is better to be kept 10 meters far away from the corresponding diffuser. The standard accessories supplied by GREE is the transition duct 200mm long and round air outlet $\phi 200$, however, those of other specifications can be purchased.

Drawings of the Air Supply Outlet and Return Air Inlet

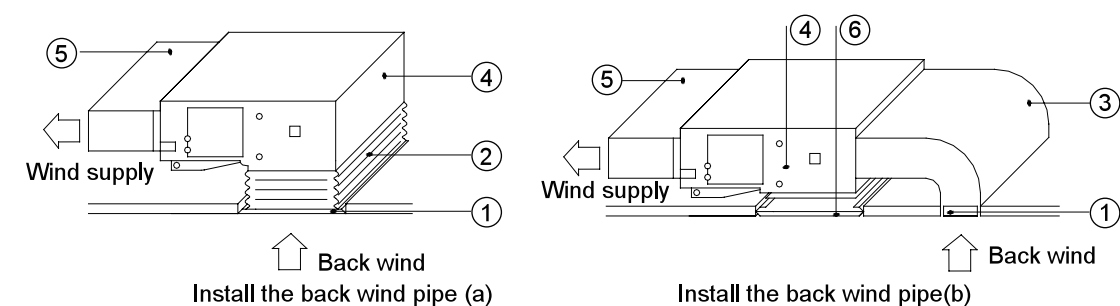

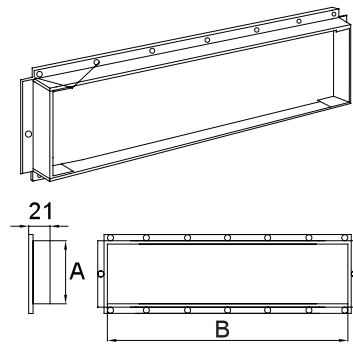

Fig.9 Air Supply Outlet



Fig.10 Return Air Inlet

Table 4 Dimensions of the Air Supply Outlet and Return Air Inlet (unit: in.)

Model	Item	Air Supply Outlet		Return Air Inlet	
		A	B	C	D
WMMS-09EF-V2B(59)2		6.1	26	23	6.4
WMMS-12EF-V2B(59)2					
WMMS-18EF-V2B(59)2		6.1	34	31	6.4
WMMS-24EF-V2B(59)2		6.1	42	38.6	6.4

Installation of the Return Air Duct

- (1). The default installation location of the rectangular flange is in the back and the return air cover plate is in the bottom, as shown in Fig.11.

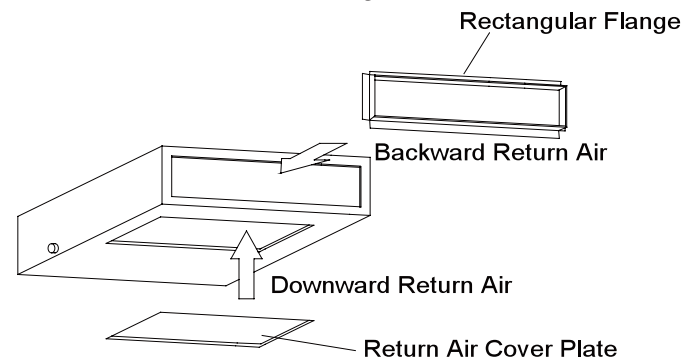

Fig.11

- (2). If the downward return air is desired, just change the place of the rectangular flange and the return air cover plate.
- (3). Connect one end of the return air duct to the return air outlet of the unit by rivets and the other to the return air louver. For the sake of the convenience to freely adjust the height, a cutting of canvas duct will be helpful, which can be reinforced and folded by 8 # iron wire.
- (4). More noise is likely to be produced in the downward return air mode than the backward return air mode, so it is suggestive to install a muffler and a plenum box to minimize the noise.
- (5). The installation method can be chosen with considering the conditions of the building and maintenance etc., as shown in Fig.12.

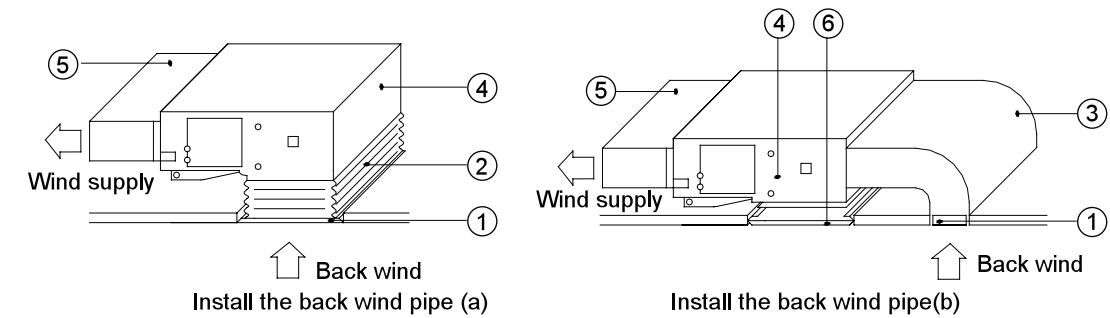

Fig.12

Table 5 Parts and Components of the Return Air Duct

No.	Name	No.	Name
1	Return Air Louver(with the filter screen)	4	Indoor Unit
2	Canvas Duct	5	Air Supply Duct
3	Return Air Duct	6	Access Grille

CONNECTING DRAIN PIPE

Installation of the Condensate Pipe

- (1). The condensate pipe should keep a inclination angle of $5 \sim 10^\circ$, which can facilitate the drainage of the condensate water. And the joints of the condensate pipe should be insulated by the insulation material to prevent condensing(see Fig.13).

Insulating Layer for the Condensate Pipe

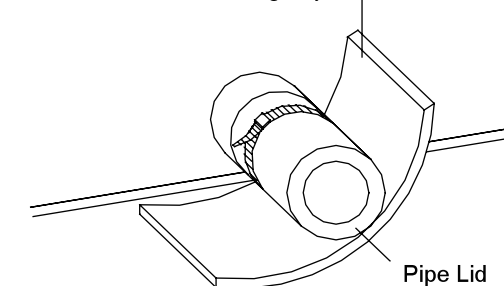

Fig.13 Thermal Insulation of the Condensate Pipe

- (2). There is a condensate outlet on both left and right sides of the unit. Once one is confirmed to be used, the other should be clogged by a rubber plug, bundled by the binding wire and insulated by the insulation material to avoid water leakage.
- (3). The right outlet is defaulted to be clogged with a plug.

CAUTION! No water leakage is allowed on the joint of the condensate pipe.

Design of the Drain Pipe

- (1). The drain pipe should always keep an inclination angle($1/50 \sim 1/100$) to avoid the water gathering in some certain place.
- (2). During the connection of the drain pipe and device, do not impose too much force on the pipe on one side of the device and the pipe should be fixed as close as to the device.
- (3). The drain pipe can be the ordinary hard PVC pipe which can be purchased locally. During the connection, inset the end of the PVC pipe to the drain outlet, then tighten it with the drain hose and binding wire but never connect the drain outlet and the drain hose by adhesive.

- (4). When the drain pipe is used for multiple devices, the public section of the pipe should be 100mm lower than the drain hole of each device and it is better to use the much thicker pipe for such a purpose.

Installation of the Drain Pipe

- (1). The diameter of the drain pipe should be larger than or equal to that of the refrigerant pipe (PVC pipe, outer diameter: 25mm, wall thickness ≥ 1.5 mm).
- (2). The drain pipe should be as short as possible and with at least a 1/100 degree of slope to avoid forming air pockets.
- (3). If the proper degree of slope of the drain pipe is not allowed, a lift pipe should be installed.
- (4). A distance 39.4~59in. should be kept between the hangers to avoid the drain hose making a turn.

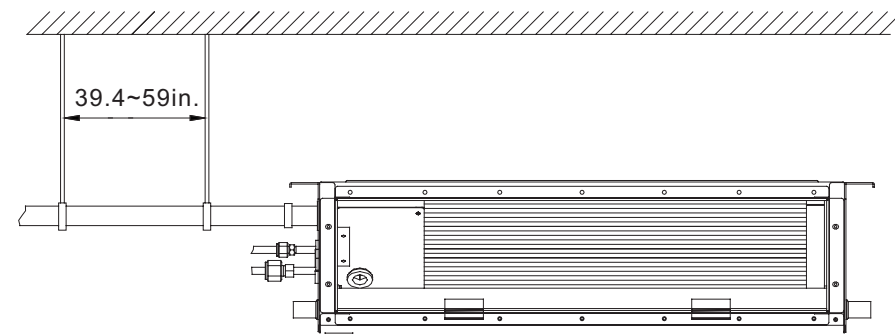

(Right) with a min. degree of slope 1/100

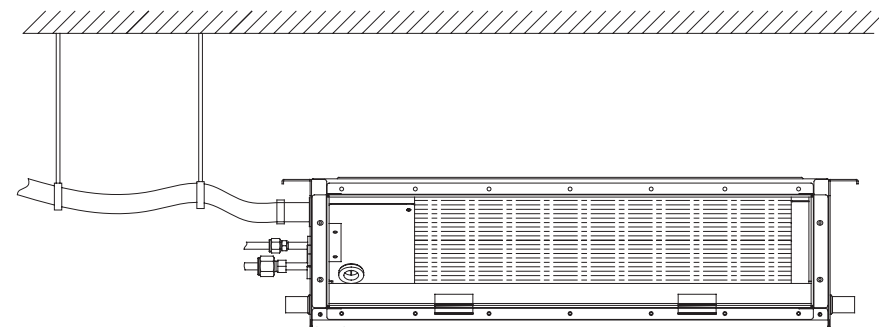

(Wrong)

Fig.14

- (5). Insert the drain hose into the drain hole and tighten it with clamps.
- (6). Wrap the clamps with large amount of sponge for thermal insulation.
- (7). The drain hose inside the room also should be insulated.

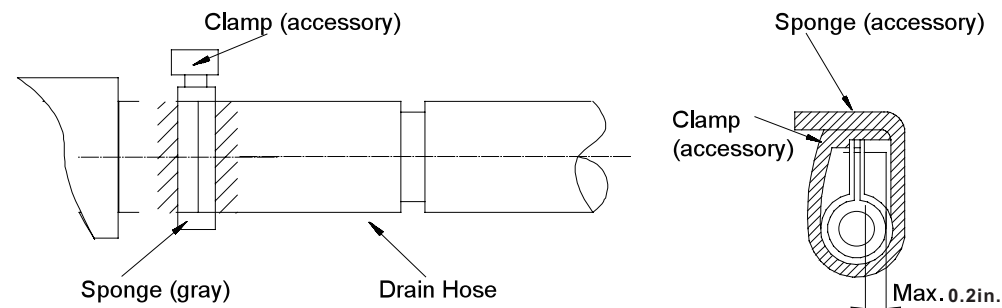

Fig.15

Precautions for the Lift Pipe

The installation height of the lift pipe should be less than 850mm. It is recommended to set an inclination angle $1^\circ \sim 2^\circ$ for the lift pipe toward the drainage direction. If the lift pipe and the unit form a right angle, the height of the lift pipe must be less than 800mm.

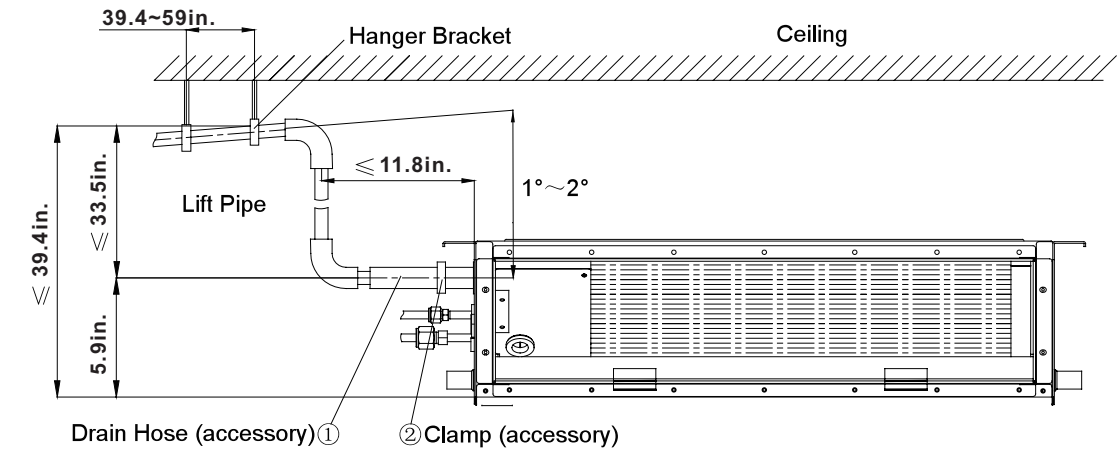
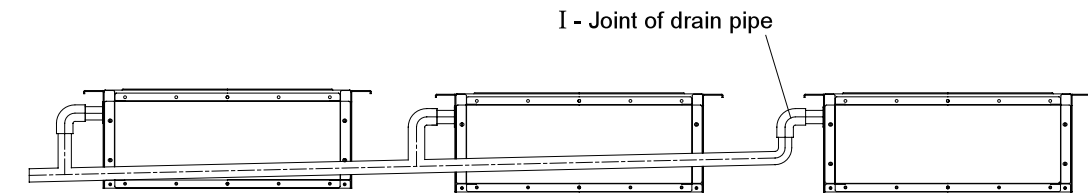

Fig.16

Notes:

- ①. The inclination height of the drain hose should be within 3in. so that the outlet of the drain hose does not suffer the external force.
- ②. If multiple drain pipes converge, please follow the installation steps below.



The specification of the joint of the drain pipe should be suitable to the running capacity of the unit

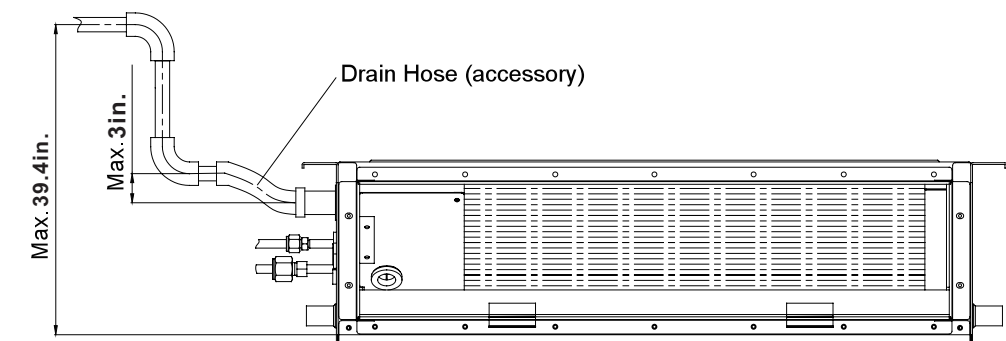

Fig.17

Test for the Drainage System

- (1). After the electric installation, please take a test for the drainage system.
- (2). During the test, check if the water flow goes through the pipe correctly and observe

carefully the joint to see if it leaks or not. If this unit is installed in the newly built house, it is suggested to take this test prior to the ceiling decoration.

Piping

- (1). Let the flare end of the copper pipe point at the screw and then tighten the screw by hand.
- (2). After that, tighten the screw by the torque wrench until it clatters (as shown in Fig.18).

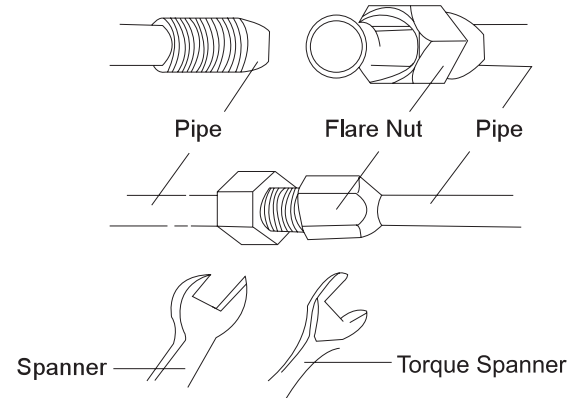

Fig.18

Table 6 Moments of Torque for Tightening Screws

Diameter of Pipe(In.)	Moment of Torque (N·m)
φ6.35 1/4	15-30
φ9.52 3/8	35-40
φ12 1/2	45-50
φ15.9 5/8	60-65

- (3). The bending degree of the pipe can not be too small; otherwise it will crack. And please use a pipe tube bender to bend the pipe.
- (4). Wrap the exposed refrigerant pipe and the joints by sponge and then tighten them with the plastic tape.

⚠ CAUTION!

① . During the connection of the indoor unit and the refrigerant pipe, never pull any joints of the indoor unit by force; otherwise the capillary pipe or other pipe may crack, which then would result in leakage.

② . The refrigerant pipe should be supported by brackets, that is, don't let the unit withstand the weight of it.

If the specification of the outdoor unit pipe joint does not conform to that of the indoor unit, then the joint specification of the outlet pipe of the indoor unit takes precedence. A reducing nipple shall be installed at the joint of the outdoor unit so as to make the joint of the outdoor unit compatible with that of the indoor unit.

Insulation for the Refrigerant Pipe

- (1). The refrigerant pipe should be insulated by the insulating material and plastic tape in order to prevent condensation and water leakage.
- (2). The joints of the indoor unit should be wrapped with the insulating material and no gap is

allowed on the joint of the indoor unit, as shown in Fig.19.

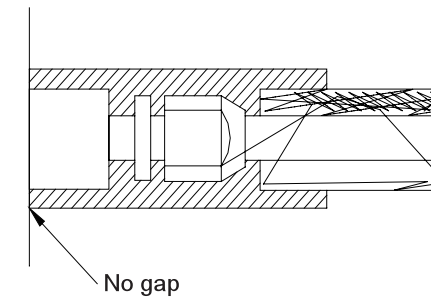

Fig.19

⚠ CAUTION!

After the pipe is protected well enough, never bend it to form a small angle; otherwise it would crack or break.

(3). Wrap the pipe with tape.

- 1). Bundle the refrigerant pipe and electric wire together with tape, and separate them from the drain pipe to prevent the condensate water overflowing.
- 2). Wrap the pipe from the bottom of the outdoor unit to the top of the pipe where it enters the wall. During the wrapping, the later circle should cover half of the former one.
- 3). Fix the wrapped pipe on the wall with clamps.

⚠ CAUTION!

① . Do not wrap the pipe too tightly; otherwise the insulation effect would be weakened. Additionally, make sure the drain hose is separated from the pipe.

② . After that, fill the hole on the wall with sealing material to prevent wind and rain coming into the room.

WIRING UNITS

Wiring between the Wire and the Wiring Terminal

(1). Wiring of the Single-Core Wire

- 1). Strip the insulating layer at the end of the wire about 25mm off with a wire stripper.
- 2). Loosen the screw off on the wiring board of the air conditioning unit.
- 3). Shape with the pliers at the end of the wire to a circle matching with the size of the screw.
- 4). Let the screw go through the circle of the wire and then fix it on the wiring board.

(2). Wiring of the Multi-Core Wire

- 1). Strip the insulating layer at the end of the wire about 100mm off with a wire stripper.
- 2). Loosen the screw off on the wiring board of the air conditioning unit.
- 3). Fix a wiring terminal matching with the size of the screw to the end of the multi-core wire with the crimping pliers.
- 4). Let the screw go through the terminal of the multi-core wire and then fix it on the wiring board.

◆ During installation, the communication cable and the power cord must not be twisted together but instead separated with an interval of at least 2cm, otherwise the unit is likely to run abnormally.

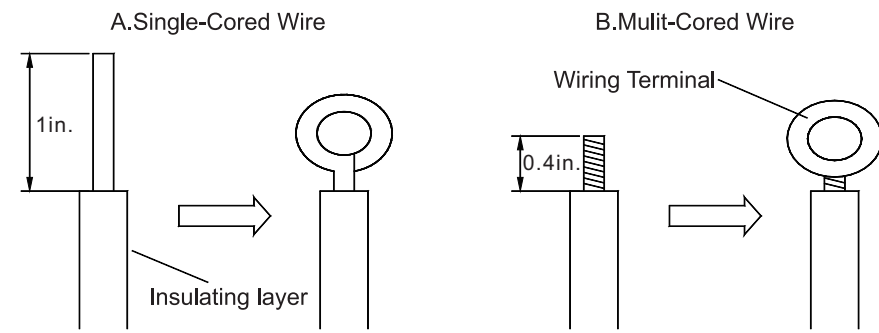

Fig.20

⚠ WARNING!

- ① . If the power cord or the signal line is damaged, they must be replaced with the dedicated one.
- ② . Prior to the wiring, please check the voltage marked on the nameplate and then carry out the wiring following the wiring diagram.
- ③ . The dedicated power cord must be used for the air conditioning unit and the electrical leakage protection switch and air switch must be installed in case of the overload condition.
- ④ . The air conditioning unit must be earthed to prevent the hazard caused by the failed insulation.
- ⑤ . During the wiring, the wiring terminal or the single-core wire must be used; the direct wiring between the multi-core wire and wiring board would cause fire.
- ⑥ . All wiring should be done strictly in accordance with the wiring diagram; otherwise the improper wiring would cause the air conditioning unit running abnormally or damaged.
- ⑦ . Do not let the electric wires touch the refrigerant pipe, the compressor, the fan or other moving parts.
- ⑧ . Do not modify the wiring inside the indoor unit randomly; otherwise the manufacturer won't assume any responsibility for the damage or abnormal running of the unit.

Wiring of the Power Cord (single-phase)

⚠ CAUTION!

The power supply for each indoor unit must be uniform.

- ① . Dismantle the cover of the electric box of the indoor unit.
- ② . Let the power cord go through the rubber ring.
- ③ . Put the 4-core cable through the hole of the chassis and the bottom of the appliance upward, and then connect the power line and the communication line from the outdoor unit to the corresponding terminals N(1), 2, 3 , and grounding terminal of the indoor unit. Wiring shall be done properly as per the wiring diagram. (Note: Be sure the wiring terminals A/B/C/D and piping joints A/B/C/D of the indoor unit match with that of the outdoor unit respectively).
- ④ . Fix the power cord tightly with the binding wire.

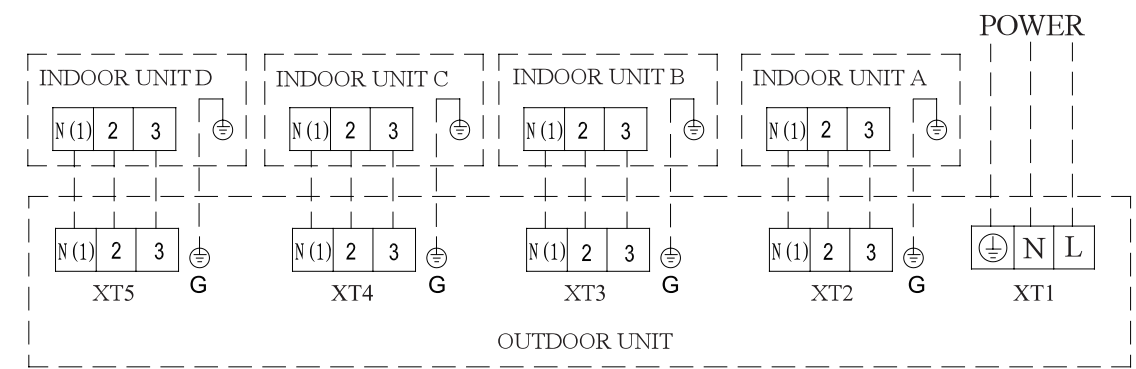

Fig.21

WMMS-60CH-V2B(59)2

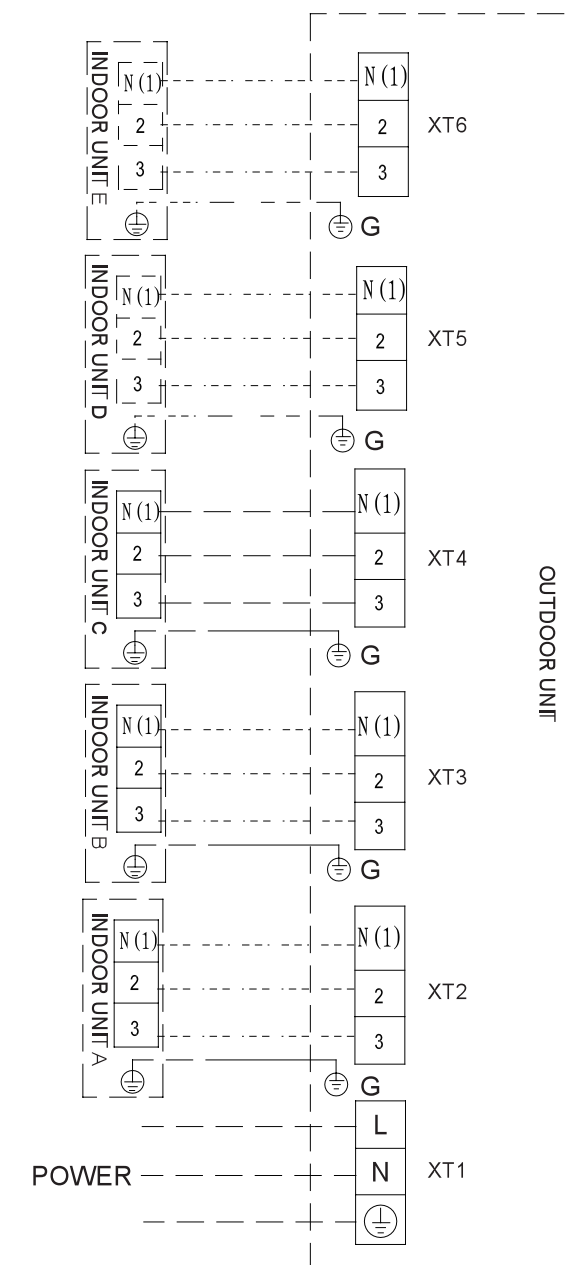

Fig.22

Wiring of the Signal Line of the Wired Controller

- (1). Open the cover of the electric box of the indoor unit.
- (2). Let the signal line go through the rubber ring.
- (3). Insert the signal line to the four-pin socket on the printed circuit board of the indoor unit.
- (4). Fix the signal line with the binding wire.

Electric Installation

Table 7

Indoor Unit		Power Supply	Running Current (A)	Input Power(W)		Recommended Power Cord (Sectional Area× Pieces)
Type	Model			Cooling	Heating	
Cooling and Heating	WMMS-09EF-V2B(59)2	208/230V~ 60Hz	0.406	75	575	AWG18×4
	WMMS-12EF-V2B(59)2	208/230V~ 60Hz	0.348	65	865	AWG18×4
	WMMS-18EF-V2B(59)2	208/230V~ 60Hz	0.428	80	1080	AWG18×4
	WMMS-24EF-V2B(59)2	208/230V~ 60Hz	0.588	110	1610	AWG18×4

Notes:

The sectional area listed above is applicable to the power cord with at most a length of 15 meters. For the longer cord, its sectional area should be enlarged to avoid the cord burning out caused by the over-current.

ELECTRICAL WIRING

Power supply and wiring requirement

- 1) Power frequency of air conditioner should be 60 Hz, voltage: AC 208/230V. If voltage is over, may cause the parts of electric equipment to become damaged. If the voltage is too low, this may cause the compressor to shake thus causing damage to the cooling system.
- 2) User power supply should be provided a reliable grounding connect. (see earth requirement)

Electrical connection requirement

- 1) Should have a reliable earth connection (see earth connection requirement)
- 2) Screw of wire should be tight, damaged screw should be changed. (Self tapping screws cannot be used on an electrical connection.)
- 3) The provided wire should be used. Please do not change the wire, length and end of it. If you need to adjust, please contact the local service center.
- 4) Please do not connect the plug with the non-plug wire by yourself.
- 5) Indoor and outdoor electrical connecting wire should not be pulled too tightly or twisted.

INDOOR UNIT CONTROL BOX & WIRING TERMINALS

Remove the control box cover and install the connection cord to the wiring terminals. Must match terminal number for each wire at both indoor unit and outdoor unit wiring terminal.

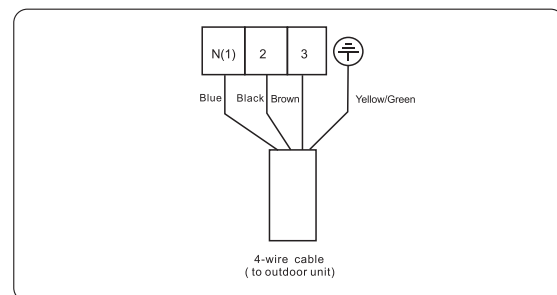
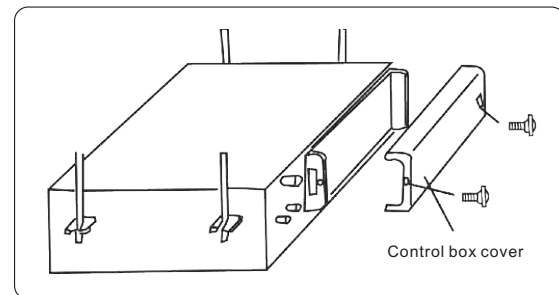

Note:

- * The temperature of refrigerant circuit will be high, please keep the interconnection cable away from the copper tube.
- * An all-pole disconnection device which has at least 3mm separation distance in all pole and a residual current device(RCD)with the rating of above 10mA shall be incorporated in the fixed wiring according to the national rule.

Earthing Requirements

- (1). The air conditioner is classified into the Class I appliances, so its earthing must be reliable.
- (2). The yellow-green line of the air conditioner is the earth line and can not be used for other purpose, cut off or fixed by the tapping screw; otherwise it would cause the hazard of electric shock.
- (3). The reliable earth terminal should be provided and the earth wire can not be connected to any of the following places:
 - ① . Running water pipe;
 - ② . Coal gas pipe;
 - ③ . Sewage pipe;
 - ④ . Other places where the technician think unreliable.

Accessories for Installation

Refer to the packing list for the accessories of the indoor and outdoor units respectively.

WIRING DIAGRAMS OF INDOOR PCB

WMMS-12EC-V2B(59)2, WMMS-18EC-V2B(59)2

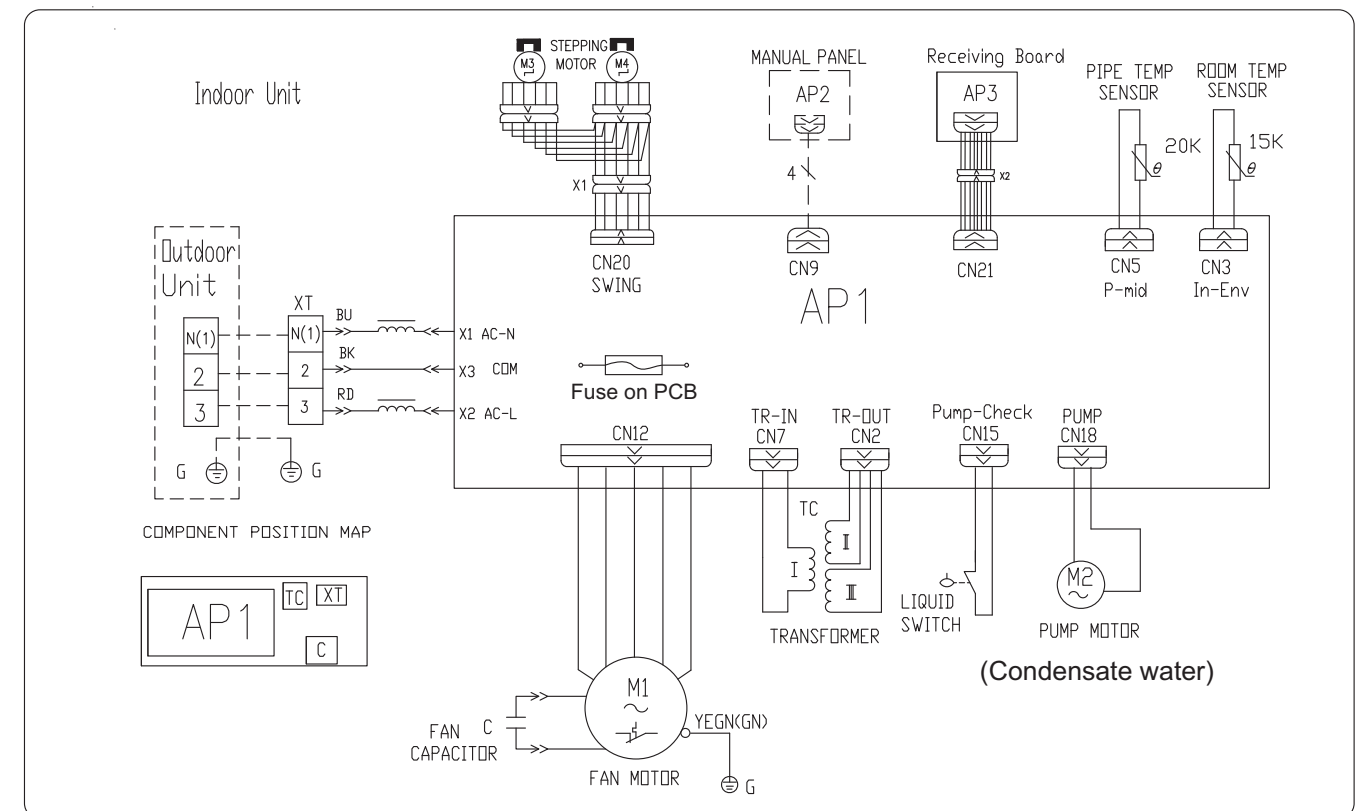

TEST AND CHECK ITEMS AFTER INSTALLATION

TEST OPERATION

1. Prepare for test

- (1) Do not turn on the power switch before all installation is finished.
- (2) Connect wires correctly and firmly.
- (3) Open the check valve.
- (4) Remove all dust.



2. Testing

- (1) Turn on the power switch and press "ON/OFF" button.
- (2) Press "MODE" button to select COOL, HEAT, FAN, etc to test whether it operates normally.

3. Emergency operation

When the unit is stopped, you can press the "AUTO" button on the cover NO II, then the unit is in AUTO mode.

* When the unit is stopped, you can press the "AUTO" button on cover NO II, then unit is in "AUTO" mode.

The air conditioner selects COOL, HEAT, DRY, FAN modes automatically.

* When operating, press the "AUTO" button, the air conditioner will stop.

NOTE:

The "TEST" button on the cover No II. is specially for testing the air conditioner.

When pressing it, the air conditioner will be forced to operate or stop. Do not press it when air conditioner is in normal operation.

For the following items, take special care during construction and check after installation is finished.







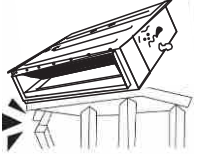

Items to check	If not properly done, what is likely to happen	Check
Is the indoor unit fixed firmly?	The unit may drop, vibrate or make noise.	
Is the gas leak test finished?	It may result in insufficient cooling.	
Is the unit fully insulated?	Condensate water may drip.	
Does drainage flow smoothly?	Condensate water may drip.	
Does the power supply voltage correspond to that shown on the nameplate	The unit may malfunction or the components burnout.	
Are wiring and piping correct?	The unit may malfunction or the components burnout.	
Is the unit safely grounded?	Risk of electric leakage.	
Is wiring size according to specifications?	The unit may malfunction or the components burnout.	
Is something blocking the air outlet or intake of either the indoor or outdoor units?	It may result insufficient cooling.	
Have records of refrigerant piping length and additional refrigerant charge been made?	Volume of refrigerant charge in the system is not clear.	

Note to the installer:

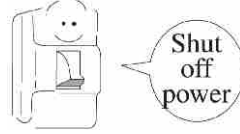
Be sure to instruct the customer how to operate the system and show him/her the attached operation manual.

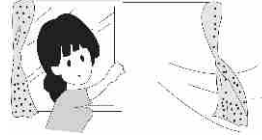
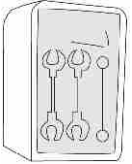
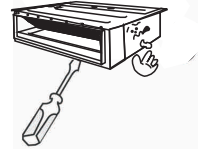
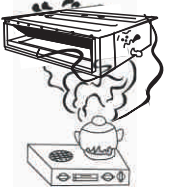
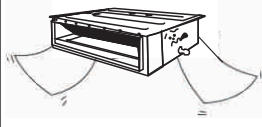
SAFETY CAUTIONS

READ THE FOLLOWING CAREFULLY BEFORE OPERATION

<p>Avoid direct air flow to your body and avoid excessive heating or cooling that may make you feel uncomfortable and do harm to your health.</p> 	<p>Check whether the installed stand is still firm enough after the unit has operated for an extended time. If a worn-out stand is left unfixed, the unit may fall and damage property or harm people.</p> 
<p>Do not remove protection grill nets from the outdoor unit. Do not put hands or insert anything into the air outlet vent of the unit.</p> 	<p>Do not stand on the outdoor unit or put anything on it. Unit may fall causing harm to self or others.</p> 
<p>If there is something abnormal (eg. burning smell), cut off the power immediately and contact service center.</p> 	<p>Do not spray any paint or pesticide on the unit, or it may cause fire.</p> 
<p>If room air is stuffy, air the room by opening door and window for a while, but close the curtains when operating the unit to prevent conditioned air from leaking.</p> 	<p>Never use wrong ampere rating fire. Use of iron wire or copper wire may cause the unit to break down or cause fire.</p> 
<p>Do not check or repair the unit while it is operating. It is very dangerous.</p> 	<p>Do not use other heating equipment near the air conditioner. It will affect the cooling performance.</p> 
<p>Never place objects near the air intake and the air outlet of the unit. It may affect performance or stop operation of the unit.</p> 	
<p>Do not splash water directly to indoor unit. It may cause harm or electric shock.</p> 	<p>Do not throw the remote control and do not press the button of the remote control with pointed object, or the remote control may be damaged.</p> 



REMOTE CONTROL-KEY NAMES & FUNCTIONS

NOTE1: This is a general use remote control and can be used for numerous air conditioner styles and models. There may be some buttons on the remote that are not for use with the unit purchased. When these buttons are pressed you may hear a beep sound emitted from the remote. This will not affect the unit status.

NOTE2: Be sure there are no obstructions between the indoor unit and the remote control. Do not drop or allow any liquids near the remote. Do not place the remote in direct sunlight or any place that can become very hot.

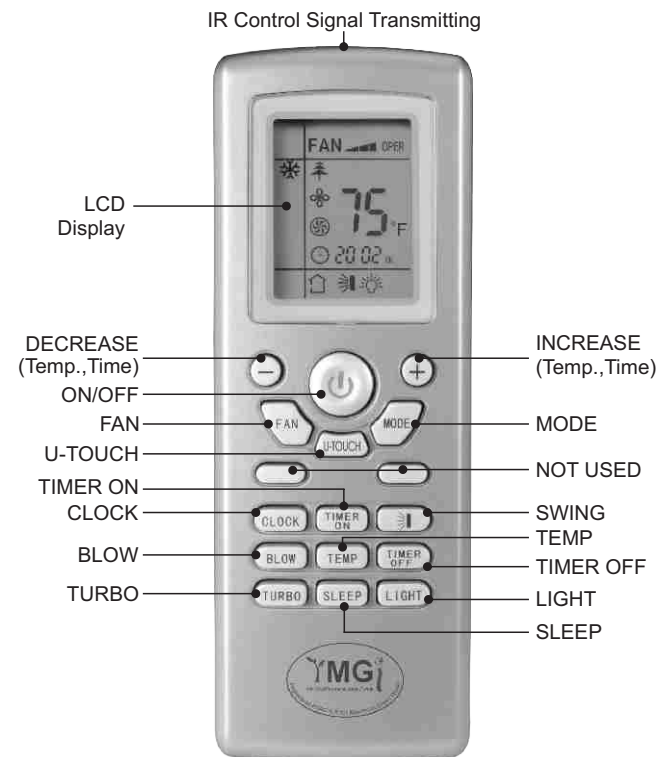

"ON/OFF" BUTTON: Press this button to turn the unit on. Press once more to turn the unit off. When turning the unit ON/OFF, the TIMER, and SLEEP functions will be canceled. The preset time will remain.

"AUTO MODE": While the unit is in AUTO the mode the temperature cannot be changed. The temperature while the unit is running in AUTO mode is 77°F. If while the unit is in AUTO mode and the room temperature falls below 77°F then the unit will run in heating mode. If the room temperature rises above 77°F then the unit will run in cooling mode. The unit will switch between the heating and cooling to maintain the factory preset temperature of 77°F.

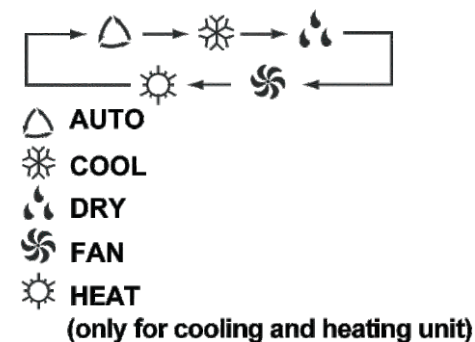

"SLEEP" BUTTON: This function will increase or decrease the set temp depending on what mode the unit is running in. When SLEEP mode is turned on in cooling mode the temp will automatically increase 0.5 to 1.0 degree once every half to one hour for several times over a period of 2 hours and remain at that temperature until SLEEP mode is turned off. When SLEEP mode is turned on in heating mode the set temp will automatically decrease 0.5 to 1.0 degree once every half to one hour for several times over a period of 2 hours and remain at that temperature until SLEEP mode is turned off. This way when the unit is in SLEEP mode during cooling the fan will blow at a lower speed to accommodate for the decreased cooling load due to less activity and a lower outdoor temp. The same principle of savings is applied to heat mode.

To activate the sleep mode press the SLEEP button once. You will see a picture of a moon and stars in the lower left hand corner. To turn off the SLEEP mode simply press the button once more and the moon and stars will disappear from the remote screen.

The COOL mode SLEEP profile is as follows:

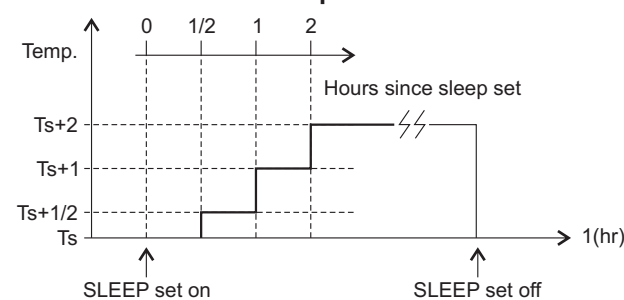

The HEAT mode SLEEP profile is as follows:

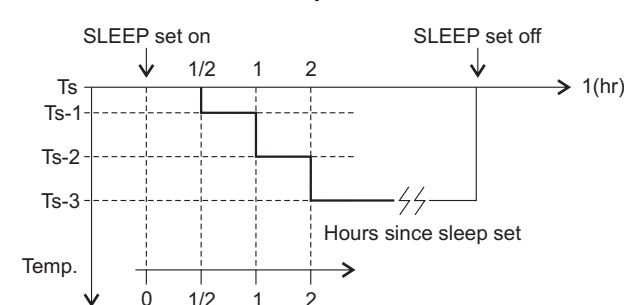

REMOTE CONTROL-KEY NAMES & FUNCTIONS

"FAN" BUTTON: By pressing this button you can select from fan speeds AUTO→Low→Middle→High. When the unit is first powered on the default fan speed setting is AUTO. When running the unit in DRY mode the fan speed will only run in low speed.

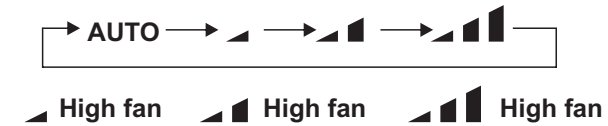

Note: Under the Dry mode, the fan speed isn't adjustable, low fan speed is imperative.

"BLOW" BUTTON: When the blow function is on a symbol on the remote will appear next to left hand corner of the temp. This feature when turned on, will allow the indoor fan to continue to blow even when the unit is turned off by the remote. This will aid in the quick drying of the indoor coil to help prevent any kind of mold build up due to moisture. To turn this feature off simply press the BLOW button once more till you notice the blow icon disappear from the remote display.

"TURBO" BUTTON: When you press this button you will see a symbol of a fan appear on the remote. In either heat or cooling mode when this button is pushed the compressor and or fan will blow at a higher speed to achieve set temp quicker. When the indoor unit senses that the set temp is being approached the fan speed will slow down. To turn this function off simply press the TURBO button until the fan symbol is no longer displayed on the remote.

"+" Button: By pressing this button the set temp will increase. If this button is pushed without releasing for over 2 seconds the temperature will increase more rapidly. In AUTO mode the temperature cannot be changed. The temperature range for this remote is 61°F to 86°F.

"-" Button: By pressing this button the set temp will decrease. If this button is pushed without releasing for over 2 seconds the temperature will decrease more rapidly. In AUTO mode the temperature cannot be changed. The temperature range for this remote is 61°F to 86°F.

"TEMP" Button: When the unit is first turned on the remote will display the last set temp. When the TEMP button is pushed twice the indoor unit will display the room temp for approximately 5 seconds before going back to the set temp.

TO LOCK THE REMOTE: If you would like to lock the remote from anyone changing the settings simply press the "+" and the "-" buttons simultaneously. When the remote is locked you will see an icon of a lock appear on the remote. If while the remote is locked and someone pushes a button on the remote they will see the icon of the remote flash three times. This indicates the remote is locked. To unlock the remote simply press the "-" and the "+" once more. You will know the remote is unlocked once the icon of the lock disappears from the remote screen.

SWITCH BETWEEN F° AND C°: The remote default is Fahrenheit. If you would like to switch between the remote displaying Fahrenheit and Celsius, press the MODE and the "-" button simultaneously while the unit is turned off.

"TIMER ON" BUTTON: This button allows you to set a time you would like the unit to turn on. The clock is a 24 hour clock. Press the TIMER ON button once and you will see the word d. By pressing either the + or the - button choose the time you would like the unit to turn on. Once you have the desired time displayed on the remote press the TIMER ON button once more and the word ON will stop blinking and stay on the remote. The time you would like the unit to turn on is now set. To cancel the TIMER ON function, simply press the TIMER ON button once more and the ON will disappear from the remote screen.

"TIMER OFF" BUTTON: This allows you to set the time that you would like the unit to shut off. Simply follow the above steps but this time press the TIMER OFF button instead of the TIMER ON button. When the word OFF is on the remote screen, the time you would like the unit to turn off is now set. To cancel the TIMER OFF function simply press the TIMER OFF button once more and the OFF will disappear from the remote screen.

REMOTE CONTROL-KEY NAMES & FUNCTIONS

"SWING" BUTTON: Hold the swing button (symbol shown above) for more than 2 seconds and the indoor air louver will start to swing between the highest and lowest limits. Once the swing button is released the louver will stay in the last position where the button was released.

If the swing button is pushed just once the swing icon will appear on the remote and the louver will swing up and down continuously between the highest and lowest points. Push the swing button once more and the icon will disappear on the remote and the louver will remain at the last point the button was pushed. When the unit is powered off by the remote the louver will close on the indoor unit.

Press this button to set up the desired swing angle which circularly changes as below. (Insert swing picture)

"U-TOUCH" BUTTON: Since the indoor unit is normally mounted high up on the wall or attached to the ceiling, the temperature at where the return air sensor is installed inside the indoor unit is higher than what it is where the area people stand and can feel (4 to 7 feet above the floor). If the unit uses the return air temperature as its target control, people may feel colder than what they really want (target) in both cooling mode and heating mode. The facts of air stratification and warm air rising and cold air dropping requires users to set up, by experiments or experience, the target temperature quite a few degrees higher than what you really want, in order to reach a satisfied or more precise indoor comfort. This is a common drawback of AC/HP units made by other manufacturers. With YMGI's U-touch feature, this can be avoided and your comfort level can be improved.

When you press the U-TOUCH button on the remote control, the unit will use the temperature where the remote is located as its target temperature control. Once you do so, you will notice a figure of a person surrounded by stars appear on the remote.

Once the U-TOUCH stars appear, the remote will send a signal of the remote-local temperature to the indoor unit, and this remote-local temperature will supersede the return air temperature as the unit's target temperature. Every 10 minutes such signal will be sent from the remote to the indoor unit updating the remote-local temperature. If at any time during this process no signal is received by the indoor unit from the remote, the unit will switch back to the previously set temperature before the U-TOUCH feature is activated. To turn the U-TOUCH feature off, simply press the U-TOUCH button until you see the symbol disappear from the remote screen. By doing so, the return air temperature will take the place of remote-local temperature as the unit's target temperature. U-TOUCH is what YOU WANT. U-TOUCH feature brings to you a true comfort level wherever and whenever you want.

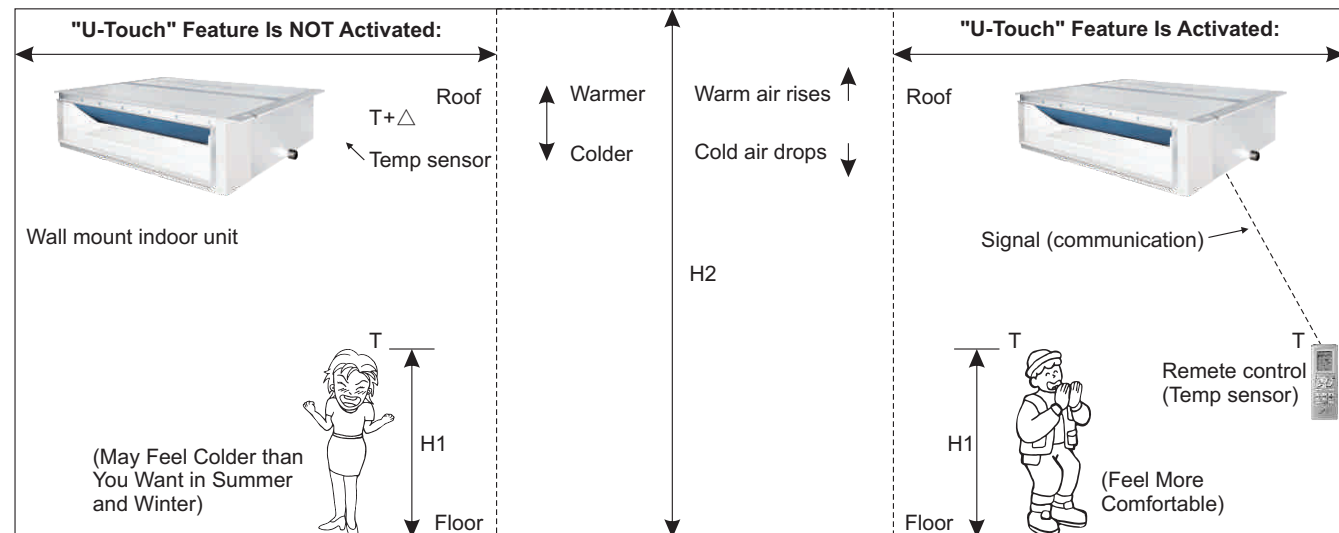

"SWING UP AND DOWN" BUTTON

Press this button, to set up swing angle, which circularly changes as below:

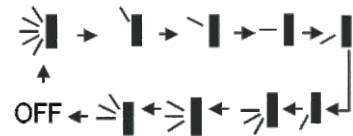

This is an universal use remote control. If remote control sends the following three kinds of status that the swing status of main unit will be:



When the guide louver starts to swing up and down, if the swing is turned off, the air guide louver will stop at the current position.

which indicates the guide louver swings up and down between that all five positions.

REMOTE CONTROL-KEY NAMES & FUNCTIONS

SYMBOL DISPLAY

When power is first applied to the unit but the power has not been turned on by the remote control, then a red power light only is displayed. When the unit has been powered on by the remote control then the running LED is lit and the current running mode symbol is displayed at the same time.

COOLING: Running symbol and cooling symbol are lit.

HEATING: Running lamp and heating symbol are lit.

DRY: Running lamp and dry lamp are lit

FAN: Running lamp and fan lamp are lit.

AUTO: Auto lamp, running lamp and actual running mode are lit.

ALPHA NUMERIC DISPLAY

* The setting temperature range for the unit is 61° to 86°F.

* Under AUTO mode unit will display 77°F for cooling and 68°F for heating modes.

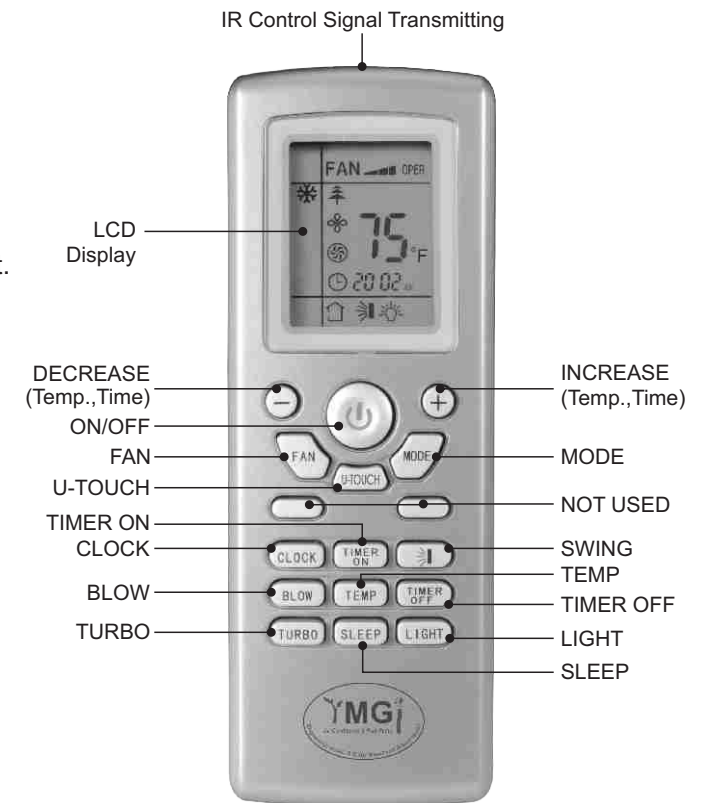

CHANGING BATTERIES AND NOTICES

- 1) Press slightly along the arrowhead direction to push the back cover open on remote control.
- 2) Take out the old batteries. (As show in figure)
- 3) Insert two new AAA1.5V dry batteries, and pay attention to the polarity. (As show in figure)
- 4) Attach the back cover of wireless remote control. (As show in figure)

NOTE:

When changing the batteries, do not use the old or different batteries, otherwise, it can cause the malfunction of the wireless remote control. If the wireless remote control will not be used for an extended period of time, it is recommended to leave the batteries out as this could cause leakage from the batteries. This will damage the remote control.

The operation should be in its receiving range.

It should be placed at where is 1m away from the TV set or stereo sound sets.

If the wireless remote control can not operate normally, please take them out, after 30s later and reinsert, if they cannot normally run, please change them.

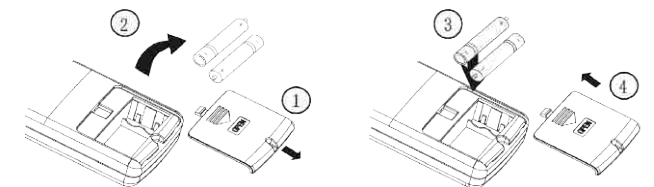

Sketch map for changing batteries

ABOUT MODE CLASH/CONFLICT BETWEEN INDOOR UNITS

If any two indoor units are controlled to run the following modes, indoor unit will run into mode clash or conflict. All indoor units will stop to run and show Protection/Error code E7, unless shut-off and then re-power:

Some on HEAT Mode, while others on COOL Mode and/or DRY(Dehumidify) Mode and/or FAN Mode.

NOTE:

COOL mode is compatible with DRY and FAN mode. In other words, there will be no problem for some indoor units to run COOL, while others may run either one or few of modes COOL, DRY (Dehumidifying) and FAN. No Protection/Error code will show up.

OPTIMUM OPERATION

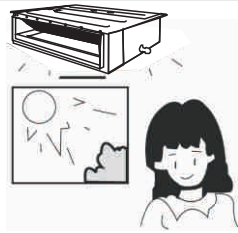
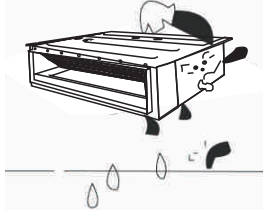
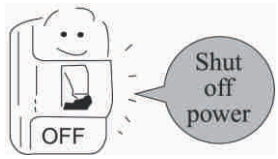
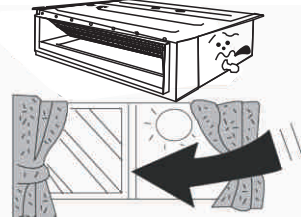
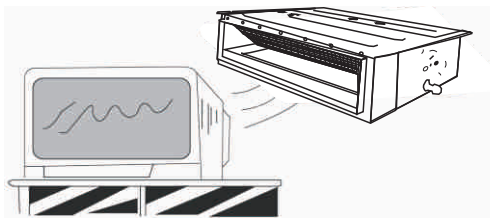
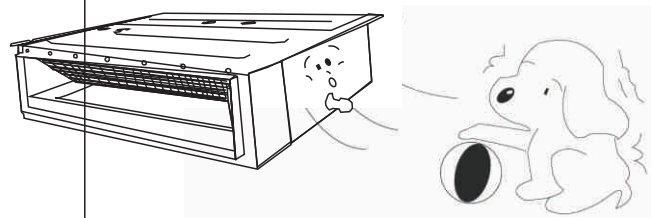
Adjust the room temperature properly	
Adjust the room temperature properly for a comfortable environment.	
Never place anything under the indoor unit that is to be kept dry	
Water may drop from the indoor unit when the humidity is over 80% or when the drainage outlet is clogged.	
Turn off the main power supply switch when it is not to be used for long periods of time	
When the main power switch is turned on, some watts of electricity is being used even if the system is not operating. Turn off the main power supply switch to save energy.	
Do not open the doors and windows for a long time when air conditioner is operating	
Cooling and heating performance will be affected if the doors and windows are open for an extended period of time.	
Place TV, radio, stereo, etc. at least 1m away from the indoor unit and the remote control	
It may cause interference in the picture or sound.	
Avoid direct air flow to pets and plants	
It may do harm to them.	

TROUBLE SHOOTING

GENERAL PROCEDURES

Notice

1) Preparation before service

- Step 1: Firstly, confirm the model of the inverter A/C which needs repairing, and then find out model of main parts that can be damaged easily and the material encode, especially the controller of outdoor unit;
Step 2: Based on the malfunction reflected by user, determine the parts that will need to be replaced, and bring tools with you for maintenance.
Step 3: As for repairing the inverter A/C, you should not only bring the common tools, such as screwdriver, wrench, etc, but also you should bring universal meter and ammeter with you.

2) During the maintenance, don't touch any terminals before the voltage between P and N of power module is measured less than 50V to avoid electric shock.

3) Before or after the maintenance, you should check whether the users power socket, terminal block on indoor/outdoor unit and all connectors on main board (especially the main board of outdoor unit, power module and PFC module) are loosened or not.

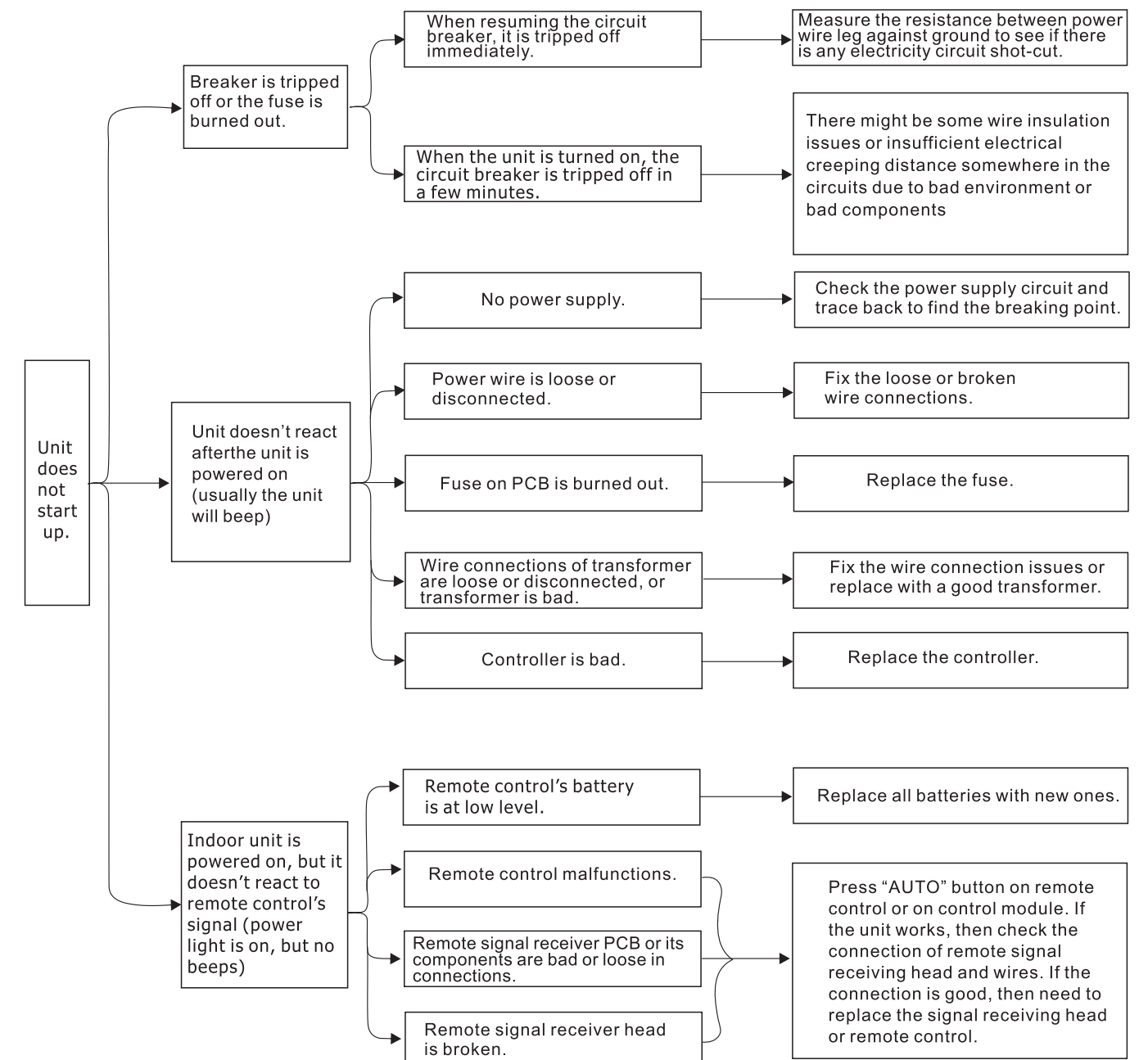

TROUBLE SHOOTING

ERROR OR PROTECTION CODE INDICATION

NO.	Error or protection codes	LED Indication		
		LED (red)	LED (yellow)	LED (green)
1	Compressor high pressure protection unit stop	Blink once		
2	Indoor unit anti-freezing protection	Twice times		
3	Low-pressure protection unit stop	Three times		
4	Air exhaust protection unit stop	Four times		
5	Over current protection unit stop	Five times		
6	Communication malfunction unit stop	Six times		
7	Unit modes conflict	Seven times		
8	Jumper malfunction	Fifteen times		
9	Defrosting/Heating oil return		Blink once	
10	Compressor overload protection unit stop		Three times	
11	System Unit malfunction		Four times	
12	IPM modular protection unit stop		Five times	
13	PFC protection unit stop		Six times	
14	Compressor malfunction		Seven times	
15	Water spill protection		Eight times	
16	Indoor ambient temp. sensor malfunction			Blink once
17	Indoor pipe temp. sensor malfunction			Twice times
18	Outdoor ambient temp. sensor malfunction			Three times
19	Outdoor pipe temp. sensor malfunction			Four times
20	Outdoor air exhaust temp. sensor malfunction			Five times
21	E2 PROM Error			Eleven times
22	Wire control ambient temp. sensor malfunction			Blink once

TROUBLE SHOOTING

When the unit is controlled by wire controller, error or protection codes are as follows:

NO.	Meaning	Code indication on display
1	Compressor high pressure protection unit stop	E1
2	Indoor unit anti-freezing protection	E2
3	Low-pressure protection unit stop	E3
4	Air exhaust protection unit stop	E4
5	Over current protection unit stop	E5
6	Communication malfunction unit stop	E6
7	Unit modes conflict	E3
8	Jumper malfunction	E3
9	Defrosting /Heating oil return	Defrost
10	Compressor overload protection unit stop	E5
11	System Unit malfunction	F2
12	IPM modular protection unit stop	E5
13	PFC protection unit stop	E5
14	Compressor malfunction	E9
15	Water spill protection	E9
16	Indoor ambient temp. sensor malfunction	F0
17	Indoor pipe temp. sensor malfunction	F1
18	Outdoor ambient temp. sensor malfunction	F3
19	Outdoor pipe temp. sensor malfunction	F2
20	Outdoor air exhaust temp. sensor malfunction	F4
21	E2 PROM Error	E3
22	Wire control ambient temp. sensor malfunction	F5

TROUBLE SHOOTING

Warning

- * In case of something abnormal (such as bad smell), shut off the power switch immediately and contact service center.
- * Do not repair the unit by yourself. Incorrect service may cause fire, please contact service center.
- * The appliance should not be used by children without supervision.

Check these items shown below before contacting service center

Phenomenon	Cause	Corrective Measures
The system does not operate at all	Power off or fuse broken	Change fuse or replace fuse
	Power off	It will restart when power is on
	Loose plug	Put the plug into place
	Batteries for remote installed incorrectly	Faulty Batteries / Install batteries properly
	Out of the remote controlling range	Keep distance in 8m or less
The system stops right after it is started	Object at the air intake and air outlet of the air conditioner	Remove them
Cooling and heating is abnormal	Object at the air intake and air outlet of indoor and out door units	Remove them
	Wrong temperature setting	Refer to REMOTE CONTROL-KEY NAMES AND FUNCTIONS
	Low fan speed	Refer to REMOTE CONTROL-KEY NAMES AND FUNCTIONS
	Air direction is not correct	Refer to REMOTE CONTROL-KEY NAMES AND FUNCTIONS
	Doors or windows are open	Close them
	Direct sunshine	Close the curtain or blind.
	Too many people in the room	
	Too many heating sources	
	Dirty air filter	Clean it

Note: If trouble still exists after checking the above items, please contact service center.

TROUBLE SHOOTING

NORMAL OCCURRENCE

Normal Occurrence	When normal occurrence happens	Cause and remedy of normal occurrence
The unit does not operate when	Restart right after stopping	Once the unit is stopped, it stays idle for about 3 minutes to protect the compressor and the unit from any potential damage
	Press SET TEMP. and then release immediately.	
	Power is switched on	Wait for 1 minute
Mist is emitted	When cooling	Room air is chilled rapidly and becomes foggy
Outdoor unit is hot	After the unit is stopped	Compressor is emitting heat to get ready for restarting
Noise	Buzz is heard at starting	It's the starting sound of thermostat and will turn low after 1 minute
	Sound of hiss like running water can be heard during operation	This is caused by the refrigerant flowing inside the unit
	A "shuh" sound which is heard at the start or immediately after the stop of operation or which is heard at the start or immediately after the stop of defrosting operation	This is the noise of refrigerant caused by flow stop and flow change
	A continuous low "shah" sound is heard when the system is in cooling operation or at a stop	The noise is heard when the drainage pump is in operation
	Cracking noise can be heard during or after operation	No need to do anything
Dust from the units	Starting operation after not using for a longtime	This is caused by the panel expanding or contracting due to temperature change in some structural parts
Discharged air smells	During operation	Dust entered into the unit and blown out at re-starting. Clean filter and coil
		This is caused by the odors in the room which have been left or kept on the filter or coil, clean the filter and coil

TROUBLE SHOOTING

ERROR CODE LIST

No.	Malfunction name	Red light (running LED)	Yellow light (heating LED)	Green light (cooling LED)	Floor ceiling dual 8	Display of wire controller	Display of wire controller for duct type unit
1	High pressure protection of system	Blink once			E1	Yes	E1
2	Antifreezing	Blink twice			E2	Yes	E2
3	Low pressure protection of system	Blink 3 times			E3	Yes	E3
4	Discharge protection	Blink 4 times			E4	Yes	E4
5	Low voltage overcurrent protection	Blink 5 times			E5	No	E1
6	Communication malfunction	Blink 6 times			E6	Yes	E6
7	Mode shock	Blink 7 times			E7	No	E2
8	Malfunction of jumper cap	Blink 15 times			C5	No	E3
9	Defrosting/heating oil return		Blink once		H1	Yes	Defrost
10	Overload protection of compressor		Blink 3 times		H3	Yes	E5
11	System is abnormal		Blink 4 times		H4	No	F4
12	Module protection		Blink 5 times		H5	No	E3
13	PFC protection		Blink 6 times		HC	No	E5
14	Out-of-step malfunction of compressor including erase malfunction		Blink 7 times		H7	No	H8
15	Water overflow protection		Blink 8 times		H8	Yes	H8
16	Indoor ambient temperature sensor is open circuit or short circuit			Blink once	F1	Yes	F0
17	Indoor evaporator temperature sensor is open circuit or short circuit		Blink 5 times	Blink twice	F2	Yes	F1
18	Outdoor ambient temperature sensor is open circuit or short circuit			Blink 3 times	F3	Yes	F3
19	Outdoor condenser temperature sensor is open circuit or short circuit			Blink 4 times	F4	Yes	F2
20	Discharge temperature sensor is open circuit or short circuit			Blink 5 times	F5	Yes	F4
21	The reserved outdoor unit displays E2			Blink 11times	HA	No	No
22	Malfunction of ambient temperature sensor on wire controller	Display the malfunction of indoor ambient temperature sensor when using this temperature sensor (Green light: blink once)				Yes	F5

TROUBLE SHOOTING

TROUBLESHOOTING

When there's malfunction or protection, the display screen of indoor unit or LED will display corresponding code and LED on main board of outdoor unit will also have warnings. Please refer to the function parts as before for details. When protection or malfunction has been eliminated, the display will resume normal status.

Analysis or disposal for some display malfunction

No	Malfunction name	Indicator			Dual 8 nixietube	Wire controller	Clauses and troubleshooting
		Red light (running LED)	Yellow light (heating LED)	Green light (cooling LED)			
1	Malfunction of jumper cap	Blink 15 times			C5	E3	The jumper cap is missed or bad on main board of indoor unit. Please check or replace the correct jumper or the main board of indoor unit.
2	Water overflow protection		Blink 8 times		H8	H8	There's connecting problem at WATER-D on main board or the water overflow switch is bad device, please check or replace it.
3	Indoor ambient temperature sensor is open circuit or short circuit			Blink once	F1	F0	The temperature sensor at ROOM on indoor main board has malfunction, please check or replace it.
4	Indoor evaporator temperature sensor is open circuit or short circuit			Blink twice	F2	F1	The temperature sensor at TUBE or TUBE-I or TUBE-O on indoor main board has malfunction, please check or replace it.
5	Malfunction of ambient temperature sensor on wire controller	Display the malfunction of indoor ambient temperature sensor when using this temperature sensor. (Green light: blink once)				F5	Replace the wire controller.

Notice:

- 1) For cassette type, floor standing type indoor unit, wire controller is optional. If the unit hasn't been equipped with the wire controller, there's no display malfunction for wire controller.
- 2) Cassette type unit only has 3 indicators, no dual 8 display.
- 3) Only the cassette type is with the error protection of water overflow. Floor ceiling type and duct type indoor fans are not built with the error protection.

CARE AND MAINTENANCE

Pull out the power plug before cleaning

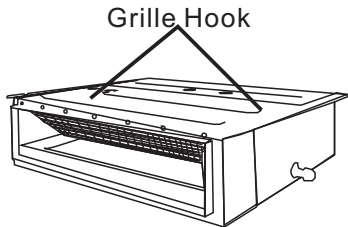
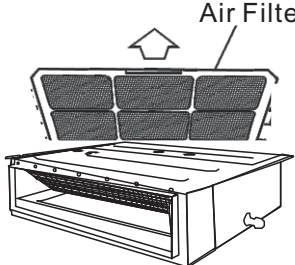
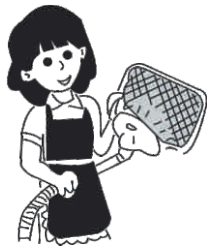
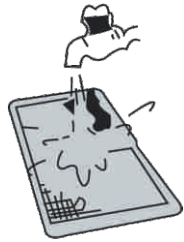
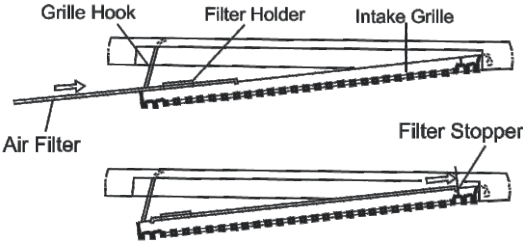

Do not splash water directly to the unit

How to Clean the Air Filter

<p>1) Open the air intake grille and use a phillips head screwdriver to remove the two screws. Slide both knobs simultaneously towards center as shown and then pull them downward slowly.</p>	 <p>Grille Hook</p>
<p>2) Remove the air filters. Slide knobs on the back of the air intake grille outward and remove the air filter. Then remove three air filters on it.</p>	 <p>Air Filter</p>
<p>3) Clean the air filter. If filters are not dirty, you can just vacuum or wash the air filter with clean water. If the air filters are very dirty. Use mild detergent and water. Leave the air filter to dry naturally in a shady place.</p> <p>Note:</p> <ul style="list-style-type: none"> * Do not clean with hot water. * Do not dry over fire. * Do not run the air conditioner without the air filter. * The suction grille must be opened carefully, air intake. 	 
<p>4) Put back the air filters</p> <ul style="list-style-type: none"> * Replace the air filter into its holder. * Make sure the air filter makes contact with the filter stopper when it is replaced into its holder. 	
<p>5) Shut the air intake grille.</p>	<p>Refer to step 1.</p>

CARE AND MAINTENANCE

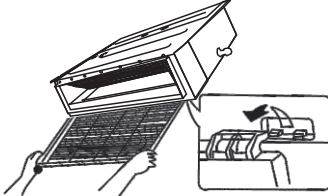
How to Clean the Air intake

<p>1) Open the air intake grille.</p>	<p>See step 1 of "How to Clean the Air Filter"</p>
<p>2) Remove the air filters.</p>	<p>See step 2 of "How to Clean the Air Filter"</p>
<p>3) Open the grille at a 45 Degree angle and then lift, it up to take away.</p>	
<p>4) Wash with water. When the air intake grille is very dirty, use soft brush and neutral detergent. Shake off water and air dry in a shady place. Attention: Do not wash with hot water.</p>	
<p>5) Replace the grille</p>	<p>Refer to step 3.</p>
<p>6) Replace the air filter.</p>	<p>See step 4 of "How to Clean the Air Filter"</p>
<p>7) Close the suction grille</p>	<p>Refer to step 1.</p>

Before Starting the Unit for the First Time in the Season

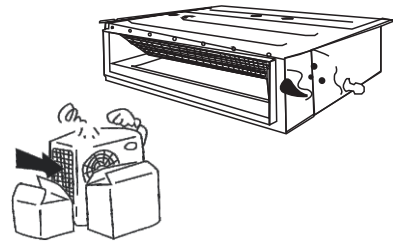
<p>1) Check to make sure no objects obstructing the intake and outlets on both the indoor and outdoor units. 2) Check to make sure ground wire is connected and that it is not damaged. 3) Check to make sure air filter has been cleaned. 4) Turn on the power 6 hours before starting the air conditioner.</p>	
--	--

End of Season Cleaning

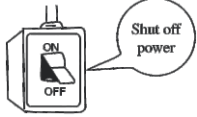
<p>1) Clean the filter and the body of the unit. 2) Turn off power. 3) Clear dust. 4) If there is any rust deep inside the outdoor unit, may need to use an extended head cleaning tool.</p>	 <p>Shut off power</p>
--	---

CUSTOMER AND TECHNICIAN MUST READ

- 11) If all the suggestions have been taken and all the necessary steps are followed.
- 12) If the contractor(s)/technician(s) are experienced with the systems/brands you purchase.
You might spend less. But remember, many times you get what you pay for.
- 13) Sign a contract with them. The contract should list all the detailed work they will conduct and the standards they will follow. Some contractors are willing to include a 1-year installation/service warranty at no extra charge. Check with them to see if that is available. If available, include that in the contract.
- 14) Verify and confirm the installation is done completely and all the unit functions have been checked and are working properly, all the items in the checklist have been checked and marked well in the warranty registration card/form, prior to paying the contractor in full.

The cost of not having your unit installed properly can be more expensive than spending a little extra money that hiring the right contractor will cost. Protect your investment and warranty eligibility by doing it right first time.

UPON PURCHASING, OPENING PACKING BOXES AND INSTALLATION OF YMGI UNITS/ACCESSORIES, YOU AND TECHNICIANS YOU HIRE TO INSTALL THEM ARE ASSUMED TO HAVE READ ALL MATERIALS AND AGREE TO FOLLOW AND BE BONDED BY ALL WE SAY IN YMGI MANUALS.

- 1) You understand all that is written hereafter in this and other documents that we publish.
- 2) You will follow what is written hereafter in this and other documents that we publish.
- 3) You will be bound by and completely follow all policies, guidelines, instructions, warnings, attentions and other materials, as published by YMGI Group, its subsidiaries or sister companies, in writing.
- 4) Only a successful installation, fully (100%) conducted by a qualified HVAC technician(s), as detailed in the checklist of the **Limited Product Warranty Policy** and **Limited Product Warranty Registration Card/Form**, along with a properly detailed installation invoice, is eligible for the **Limited Product Warranty**.
- 5) Failure to follow what is written hereafter may cause various equipment issues that you will take full responsibility and liability for, including, but not limited to, losing manufacturer's warranty, unit not working properly, unit malfunctions, under-performance, decreased safety, increased potential of various damages to your property, body, home and/or business, etc.
- 6) YMGI documents and policies supersede those made or provided by the sales distributors or installing contractors. YMGI Group maintains the final authority in explaining and resolving any and all discrepancies that might exist between distributors/contractors' documents and ours.

YMGI STRONGLY RECOMMENDS:

- * Customer hires a currently licensed/ certified HVAC technician(s) (N.A.T.E. or A.C.C.A certification is strongly recommended) to conduct 100% of the installation, inspection of all unit functions and repair service.
- * Customer signs an installation/service contract with the installation/service technician's company who has good service references and you trust. Installation and service is very important to the life of your investment and provide you a lifetime of comfort and peace of mind.
- * Customer requests the installer to put down a 1-year labor warranty coverage in the installation contract.
- * Have the technician check against all the items in the checklist of the **Limited Product Warranty Registration Card/Form**, sign and date it, to help ensure a proper and professional installation.
- * Customer pays in full, only after all the unit functions are inspected, the unit works properly, warranty checklist is fully filled out and signed and you are fully satisfied.
- * If any unit abnormality is found, have your technician check the unit first. Have them call for manufacturer technical assistance, if necessary, from your job site, not his office, so that we can more accurately assist him in diagnosing the cause of the malfunction.

QUESTIONS ABOUT SELF-INSTALLATION VS HIRING LICENSED HVAC TECHNICIANS

Does YMGI allow to do-it-yourself installations (DIY) partially or fully? NO.

Unfortunately no brand or manufacturer can take the responsibility of the equipment if it is not professionally installed by a currently licensed HVAC technician/ contractor.

If unit is installed by non-licensed people, in part or fully, will the factory warranty be void? YES.

CUSTOMER AND TECHNICIAN MUST READ

Some DIY installations have been successful, but these are exceptions. Most have resulted in equipment failure, due to lack of knowledge and experience. A few of the problems result from DIY's lack of knowledge in the following areas:

- * Sizing and selecting correct type, size and model of cooling and/or heating equipment.
- * Sizing and installing correct electric circuit breakers and wires.
- * Wiring the units correctly and properly.
- * Taping the ends, connecting to indoor and outdoor units correctly and properly.
- * Vacuuming the inter-connecting refrigerant lines.
- * Checking and/or fixing the refrigerant leaks.
- * Checking and/or fixing the condensate drain leaks.
- * Releasing the refrigerant from outdoor unit to indoor unit.
- * Running the unit to check all the unit functions.
- * Conducting the installation or trouble-shooting with correct tools, experience or professional knowledge to correct the problem.

RECEIVING AND FREIGHT DAMAGE

- * Freight (package/unit) shall be checked thoroughly for damage at receiving before accepting by signing on the carrier's delivery paperwork.
- * Upon shipment being signed for acceptance, it becomes a binding document as to the condition of the products on delivery. We cannot process any shipping damage claim, if you accept the delivery.
- * If damage is found at delivery, both you and the delivery driver must make notes on the delivery receipt or other freight paperwork detailing the damage found by marking position/parts on unit, description of damage, time/date, your name, contact phone, etc. on the delivery documents. Make a copy of the marked delivery receipt.
- * If the damage is minor or partial, that you choose to accept, you can contact the distributor or YMGI to discuss the possible replacement of the damaged part.
- * If refusal of the shipment is needed due to severe freight damage, **DO NOT** sign the carrier's delivery receipt document indicating that you accept the products. Mark receipt "REFUSED DUE TO FREIGHT DAMAGE." Sign and date along with the delivery driver's signature and date.
- * Take pictures showing the damage, before the delivery driver leaves.
- * If you accept the delivery or fail to note damage on the driver's delivery receipt, the ability to claim freight damage is lost and YMGI will not replace the unit on this basis.
- * Contact the distributor or YMGI, report the damage by forwarding the marked delivery receipt copy and pictures.
- * Only after YMGI verifies with the carrier the necessary detailed notes of received freight damage, will the damaged products be eligible for replacement.
- * If the returned products are found not damaged, YMGI will treat it as a return and will charge you 25% of product value plus added shipping cost.

RETURN-YMGI GROUP POLICIES & RETURN GOODS AUTHORIZATION (RGA)

All sales are final. If the customer wishes to return a product, the following **Return Policies** apply.

A. Only those products (units, parts or accessories) under the following conditions, are eligible for return:

1) Products are returned within 30 days of their original shipment date from YMGI

- 2) Products have not been installed.
- 3) No damage exists on the products being returned.
- 4) No missing products.
- 5) Products and packages are clean.
- 6) No duct tape or marking on the product or box.
- 7) Products are still their original package, in good shape and in re-sellable condition, as YMGI determines.

B. Preapproval steps for your return request:

- 1) Contact your distributor or YMGI to request a return.
- 2) Photograph your product and box to show details
- 3) YMGI will review your request, along with the pictures and any other details pertaining to your request.
- 4) If YMGI agrees to process your return request, a form called **Return Goods Authorization (RGA), along with an assigned RGA #** will be forwarded to your distributor or you.
- 5) Any return without YMGI Group approved RGA #, will not be accepted.



CUSTOMER AND TECHNICIAN MUST READ

C. YMGI must verify the following before you can pack your products:

- 1) No products (units, parts, accessories) are missing.
- 2) No damage is found.
- 3) The products are in the original packaging.
- 4) No duct tape on any product or box.
- 5) Pictures have been taken and sent to YMGI to verify the product and boxes are not damaged.
- 6) The RGA has been completed and a copy has been returned to YMGI, via email or fax.
- 7) YMGI has approved the request in writing.

D. Shipping Preparation:

- 1) Package all products in a manner in which no damage can occur to the product and secure to a pallet.
- 2) Take and forward pictures of packed pallets for YMGI to verify proper packaging and no existing damage.
- 3) Include the YMGI approved RGA# in the shipping documents.
- 4) YMGI reserves the right to approve or deny any shipments.
- 5) YMGI can arrange shipping for you, but not at YMGI's cost. If this option is chosen, a packing list and BOL will be issued to you through YMGI.
- 6) If the above option is not chosen, you will be responsible for all freight charges. YMGI will not accept any returned items COD.
- 7) Place the package in an area which is accessible to the shipping company for pickup and limits the possibility of damage to the product. Customer must be present at the time of freight pick up.

After shipping, fax the BOL to YMGI Group at 1-866-377-3355 or email to customerservice@ymgigroup.com, detailing the information of the freight company and their tracking number.

E. Freight Damage:

- 1) YMGI Group will inspect returned items
- 2) Claiming of freight damage from a customer hired carrier will be the customer's responsibility.
- 3) Claiming of freight damage from a YMGI hired carrier will be YMGI's responsibility.

F. Charges for your return:

- 1) A restocking charge of 25% creditable invoice value.
- 2) All return shipping fees.
- 3) Additional fees will be charged, if products are found to be damaged, missing or used.
- 4) YMGI will notify the distributor of the charges only after the inspection and assessment of the returned products has been completed.

Attention:

- 1) Returned products must be shipped within 7 days of YMGI's releasing of **RGA #**.
- 2) **All RGA** shipping shall be prepaid by the customer. **YMGI will not accept any COD freight.**

YMGI GROUP DISCLAIMING-1:

YMGI Group will NOT accept any return, or may not honor 100% credit for any return of Product(s)/Part(s)/Accessories, in any of the following cases:

- * Return requests made 30 or more days after the date of original sales shipping from YMGI Group warehouse.
- * Return shipment is initiated 8 days or more after the RGA is approved.
- * Returned products received not displaying an YMGI-approved valid **RGA #**.
- * Returned products received C.O.D.
- * Returned products not received in the original packaging.
- * Returned products received with non-repairable packaging, including duct tape or marks on units or carton boxes.
- * Returned products received with missing units/parts/accessories.
- * Returned products received, are found to be non-functional or damaged.

YMGI GROUP DISCLAIMING-2:

- * YMGI Group will not be responsible for any losses of returned unit(s)/part(s)/accessories in transition to YMGI Group warehouse.
- * YMGI Group RGA is valid for seven (7) days from the original issuing date. Returns will not be accepted, if shipping is made 8 or more days after the YMGI Group RGA is issued.

CUSTOMER AND TECHNICIAN MUST READ

DEFECTIVE UNITS / PARTS / ACCESSORIES-REPAIR OR REPLACEMENT

Out of thousands of units sold every year, there may be an occasional instance your product does not operate properly. Reasons of but are not limited to: **manufacturing, installation, operation, maintenance and knowledge of operator.**

Equipment failure does not automatically denote a product defect from the factory assembly line. The defects can be caused, during production, transportation, installation, operation, maintenance, or service. Defects may NOT be the responsibility of the manufacturer. Nobody willfully or intentionally produces a defective product. No determination shall be made until the technical issue(s) or the causes of the defect(s) are identified.

The defects might be found before/ during installation or in the operation of the unit. Defects can be in the form of blown fuse(s), defective control board(s), damaged remote control, loose or missing screws, etc. These defective parts can be replaced easily.

Some functions of our units are different from what are typical in traditional split type air conditioning and heat pump systems and similar systems made by other manufacturers. These are not defects. Take some time to learn the functions of your unit. We will be happy to assist you with any questions you may have concerning the functions of your new unit.

If a defect is found, whether at the original installation, or during normal operation, we will gladly help you in the following steps in sequence from 1 to 3:

1. **Part repair or replacement after trouble-shooting:** This is the most common and generally the easiest and most economical way for all the needed parts since the problem and all part needs can be accurately and completely identified.

* Your technician calls our technical support line, from your job site, after checking your units and getting all the information ready.

* Our technical support will go through several steps, over the phone or through email, with your technician, in order to help identify and resolve the problems. Normally wiring correction, piping correction, part repair/ replacement will resolve the problems.

* Your technician will then need to verify and confirm the problem(s) before YMGI can ship out the replacement part(s). Inaccurate or incomplete troubleshooting or part replacement will delay the repair. YMGI technical support will only speak with a licensed/certified technician in regards to the repair of your unit. In our experience this saves time and money for all parties involved.

Your technician is the only person to perform any physical checking, trouble-shooting and replacing of any defective part(s) for your units. Our factory technical support is just a help. **YMGI provides no labor warranty on the products.**

2. **Unit/part repair at our workshop(s):** Due to the limitations of our technical support not being at your job site, or your technician's limited experience with our product, the problem may not be resolved as quickly as would be desired. If the problem is still not resolved after attempts between your technician and our technical support, you can elect to have the unit repaired at our facility. If this step is chosen:

- 1) YMGI will send to you the **Customer Request to Ship Products to YMGI Service Center for Inspection and Repair, and Authorization to Charge** form.

- 2) You will review the form and fill all fields appropriately, sign and send back to the YMGI Group.

- 3) Once the form has been completed and sent back to YMGI, remove the units and ship back to YMGI.

Please make a note describing the problem and communication history, if possible. Our technicians will check the units and find the problem(s), repair the issue(s), and ship the unit back to you following the conditions set forth in the signed repair agreement. All unit removal and re-installation is done at your cost and must be done by a currently valid licensed HVAC technician.

3. **Unit replacement:** Only applies to those defects reported within 30 days of original purchase date and if all necessary warranty paperwork had been received and approved. This option applies only if the above steps cannot resolve the problem(s). Either indoor or outdoor unit replacement is available, based on the actual need, at YMGI's determination. ***This option shall be the last resort***, due to refrigerant and wiring considerations. All unit removal, re-installation and shipping cost are the responsibility of the customer. YMGI maintains the final authority as to unit replacement. Replacement will be made with the same model only. Alternate units will be treated as a new order.

Returning Replaced Defective Units/Parts/Accessories After Unit Repair: (Only applies to steps 1&3 above)

- 1) Repack the replaced unit/ part /accessory in the box which contained the replacement part.

- 2) Parts can be boxed for UPS, FedEx or equivalent ground service. Units shall be secured onto the skid on which the replacement was shipped after placing into the package from the replacement product.

- 3) Ship **all** replaced products, to YMGI-designated location. You will be charged if YMGI does not receive the replaced parts.



CUSTOMER AND TECHNICIAN MUST READ

Standard factory warranty does not cover the cost of materials and labor that are incurred at your site. There will be no cost for the replacement unit, if YMGI determines the defect is manufacturer related. Replacement will be made with the same model, only. Alternate units will be treated as a new order.

CUSTOMER SERVICE / TECHNICAL SUPPORT FROM YMGI GROUP

For questions or help with your unit, contact the original installer or service provider.

YMGI Group does not install nor physically service your unit. Your installer or service provider must check the unit prior to contacting YMGI Group from your jobsite, in order to be helped in an efficient and timely manner.

* Factory customer service at customerservice@ymgigroup.com Tel: 1-866-833-3138x704

* Factory technical support at techsp@ymgigroup.com Tel: 866-833-3138x703

* Fax: 1-866-377-3355

An "**YMGI Group Customer Service/Technical Support Daily Log Sheet**" will be filed in writing at our office, for effective communication between you and YMGI Group customer service, your technician and YMGI Group technical support. Before contacting the YMGI Group locate the IP# written at the top of your warranty registration form. Use this IP# whenever you contact the YMGI Group.

DISTRIBUTOR AND MANUFACTURER POLICIES

* All questions concerning sales or money will be directed to the sales distributor from which you purchased the units.

* Read and follow all policies set forth from the distributor from which you purchased your unit.

* Upon purchase and installation of the unit(s), you agree to be bounded by all policies published by both distributors and YMGI.

* YMGI Group has the final authority and supersedes other related parties (distributors, etc.) concerning all policies regarding YMGI products.

YMGI DISCLAIMING-3 (RE: LIMITED PRODUCT WARRANTY)

- 1) The YMGI **Limited Product Warranty Policy**, details the eligibilities, coverage's and other explanations of the warranty terms between YMGI group and the unit owner.
- 2) The YMGI **Limited Product Warranty Policy** and the **Warranty Registration Card/Form** are either included inside the user's manual and/or installation instruction manual, or come separately in the unit packaging box/ envelope. If for any reason they are not included with your shipment, contact our sales or customer service to request a copy (electronic or printed), prior to installation.
- 3) The checklist, in the **Warranty Registration Card/Form**, is for the currently licensed/ certified HVAC technician to fill out completely, while verifying all unit functions are operating correctly. This checklist is for the technician to test and check all details of your unit, to verify and ensure its proper operation.
- 4) The technician must complete all fields in the **Warranty Registration Card/Form**, especially the unit model and serial numbers and distributor information, and most importantly, the technician checklist.
- 5) **Warranty Registration Card/Form** shall be mailed, **along with the original copy of the currently licensed HVAC contractor's full installation invoice**, to YMGI Group, within 7-days after original installation, in order for YMGI to review and process your warranty registration.
- 6) Keep a copy of **Warranty Registration Card/Form** for your own use in the future, to aid in any possible future warranty claiming, any request of parts, customer service, and/or technical support.
- 7) YMGI reserves the right to approve or deny the warranty status based on the information reviewed.

Mailing address of the **Warranty Registration Card/Form**: Warranty Department, YMGI Group, POB 1559, O'Fallon, MO 63366, USA.

USER NOTES AND INSTALLATION/SERVICE/MAINTENANCE NOTES

USER NOTES

Put down whatever questions you have or problems you have seen as a unit history:

No.	Date	Notes	Asked for Your Technician for Help?	Did You Ask YMGI Tech. for Help?

INSTALLATION NOTES

Put down whatever questions you have or problems you have seen as a unit history:

No.	Date	Original Installation Company Name, Technician Name, Phone & HVAC License #	Job Not Performed by Technician	Technician Checklist Completed Fully?

SERVICE / MAINTENANCE NOTES

No.	Date	Contents of Service / Maintenance	Technician's Company Name, Technician Name, Phone & HVAC License #

